

# GR DIGITAL

# RICOH

## Camera User Guide

The serial number of this product is given on the bottom face of the camera.

- |   |   |
|---|---|
| 1 | Quick Guide                               |
| 2 | A Variety of Shooting Techniques/Playback |
| 3 | Changing Camera Settings                  |
| 4 | Installing Software                       |
| 5 | Troubleshooting                           |



## Caution!

### Do not connect the USB cable yet!

If you connect the camera to a computer through the USB cable before installing the provided software on the computer, the software required for connection between camera and computer may not be installed appropriately.

Be sure to connect the camera to your computer after installing the provided software.

For how to install the software, see P.152.

### About other documentation

Detailed explanations on how to use the provided software can be found in "Software User Guide" (PDF format file) included on the supplied CD-ROM.

For how to display the PDF file, see P.167.

The CD-ROM also contains English version of Camera User Guide and Software User Guide in PDF format.

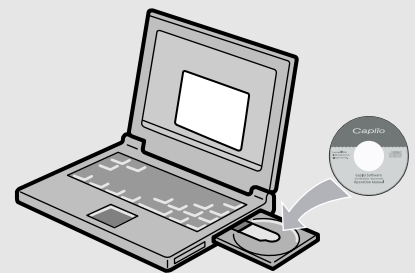

# Preface

This manual provides information on how to use the shooting and playback functions of this product, as well as warnings on its use. To make the best use of this product's functions, read this manual thoroughly before use. Please keep this manual handy for ease of reference.

Ricoh Co., Ltd.

<b>Safety Precautions</b>	For the safe use of your camera, be sure to read the safety precautions thoroughly.
<b>Test shooting</b>	Please be sure to do some test shooting to make sure it is recording properly before normal use.
<b>Copyright</b>	Reproduction or alteration of copyrighted documents, magazines, music and other materials, other than for personal, home or similarly limited purposes, without the consent of the copyright holder is prohibited.
<b>Exemption from Liability</b>	Ricoh Co., Ltd. assumes no liability for failure to record or play back images caused by malfunction of this product.
<b>Warranty</b>	This product is manufactured to local specifications and the warranty is valid within the country of purchase. Should the product fail or malfunction while you are abroad, the manufacturer assumes no responsibility for servicing the product locally or bearing the expenditure incurred thereof.
<b>Radio Interference</b>	Operating this product in the vicinity of other electronic equipment may adversely affect the performance of both devices. In particular, operating the camera close to a radio or television may lead to interference. If interference occurs, follow the procedures below. <ul style="list-style-type: none"><li>• Move the camera as far away as possible from the TV, radio or other device.</li><li>• Reorient the TV or radio antenna.</li><li>• Plug the devices into separate electrical outlets.</li></ul>

- This publication may not be reproduced in whole or in part without the express written permission of Ricoh.  
© 2005 RICOH CO.,LTD. All rights reserved.
- The contents of this document may be changed in the future, without prior notice.
- This booklet was created with thorough attention to its content. If, however, you have a question, spot an error, or find a description lacking, please refer to the end of this booklet for information on how to contact us.

Microsoft, MS, Windows and DirectX are registered trademarks of Microsoft Corporation in the United States of America and other countries.

Macintosh, Power Macintosh, and Mac OS are registered trademarks of Apple Computer, Inc. in the United States of America and other countries.

Adobe and Adobe Acrobat are trademarks of Adobe Systems Incorporated.

All trademarked company and product names mentioned in this manual are the property of their respective owners.

# Key Features

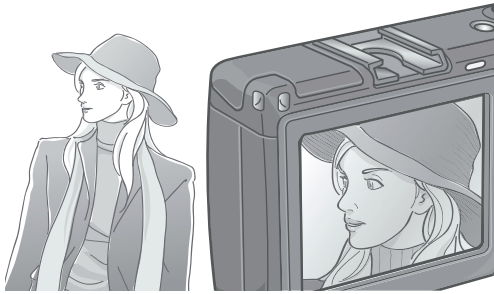

## High-quality and -definition camera ready for professional use

The advanced technology for remarkably high-quality photography adopted for the camera fits well inside a compact body. The CCD with 8.13 million effective pixels achieves high image quality enough to satisfy professionals. The camera also achieves high-speed processing of voluminous data while suppressing image noise, enabling crisp, definite prints on large-format paper.



## High-end model with aperture priority, manual exposure, and program shift modes

The aperture and shutter speed can be set with an easy-to-operate up-down dial. The high-end camera features compactness, lightweight, and slimness, as well as an ability comparable to that of a digital single-lens reflex camera.



## Rapid shutter response to capture a moment (P.36)

The shutter release time lag is as short as approx. 0.1 seconds. Ricoh's patented hybrid auto focusing system technology even keeps action shots looking good.



## Close-up flash (P.43) for approx. 1.5-cm macro (P.44)

The unsurpassed macro function allows you to capture details from a very close distance at only 1.5 cm. The close-up flashing capability provides you with clear macro shots even under low light conditions.

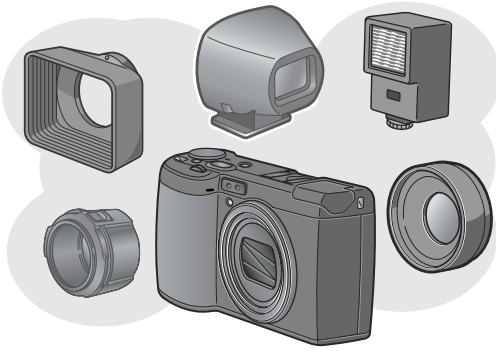

## Expandability sparking the imagination

The wide conversion lens combined with the hood and adapter gives super-wide 21 mm photography. You can enjoy the benefits of bounce flash by connecting an external flash. Various optional accessories such as the external viewfinder and cable switch allow you to configure a well-rounded system.

## AF target shift function for easy focus lock even on a tripod (P.94)

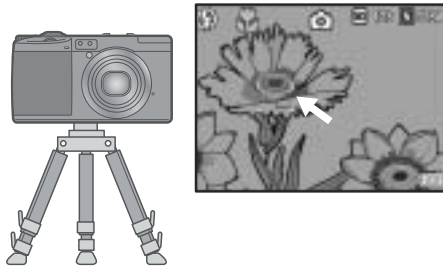

The camera has an AF target shift function. At macro shooting, the AF target shift function allows you to lock the focus by button operation, without moving the camera itself.

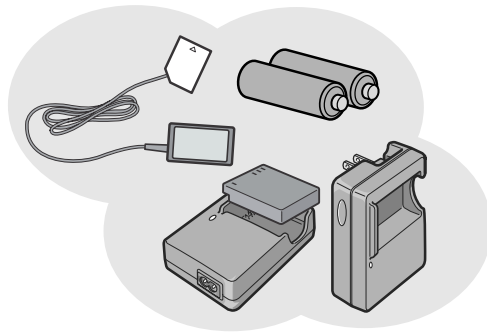

## Choice of three power sources makes sure you won't miss any shooting opportunities (P.19)

The camera can be used with one of three power supplies: Dedicated large-capacity rechargeable battery, an AAA alkaline battery easily available anywhere (available in stores), and an economical AC adapter (sold separately) useful for transfer to a computer.

## Two dials for easy and speedy operation

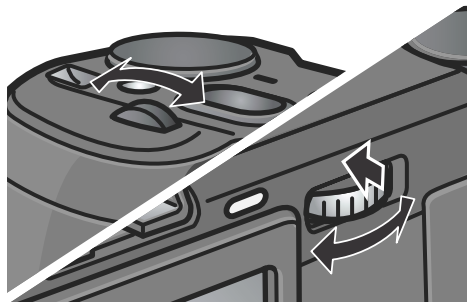

The up-down and ADJ. dials let you make settings and select menu options more quickly than ever before.

The ADJ. dial allows you to enter the ADJ. mode where you can correct exposure and white balance with fewer operations. You can also customize functions other than these adjustment functions with the ADJ. dial.

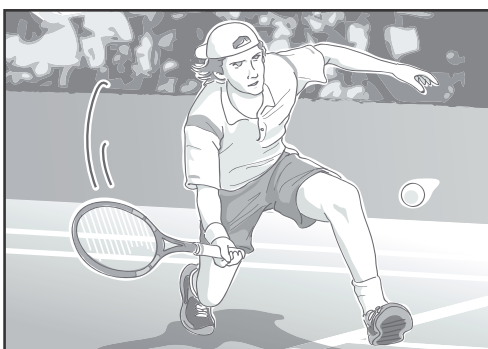

## High-quality movie with sound of 30 frames/second (P.105)

A high-quality movie of 320 x 240 pixels can be shot at 30 frames/second with sound.

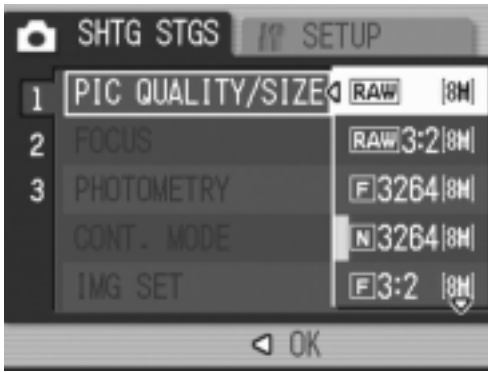

## RAW mode ensuring shooting at the highest quality

The camera's RAW mode gives you an option to save full data of shot images in the uncompressed RAW format (.DNG files). The image quality of RAW files degrades little as compared with JPEG files and you can create images as expected by processing them on the computer. JPEG files converted from RAW files are also recorded.

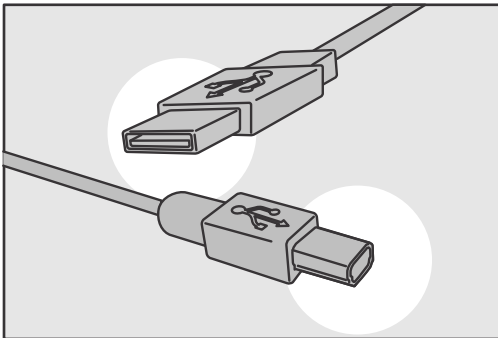

## Instant transfer to PC through the USB cable

If the provided software is installed on your computer, just connecting the camera to your computer with the provided USB cable will automatically transfer images to your computer.



## Provided with multi-functional software "ImageMixer" that helps in not only managing shot images in an album, but also editing images and sounds, and creating video CDs

For the integrated handling of images, this software has a input function to download still images, movies, and sounds from a digital camera or music CD, an album function to manage captured contents, an edit function to edit movies by MPEG-1, a layout function to create layouts using still image contents, and a disk creation function to create video CDs.

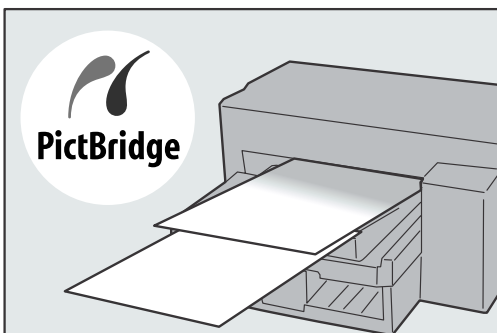

## Direct printing without requiring any computer (P.60)

A direct print compatible printer can be connected to the camera with the USB cable for direct transfer. This allows for easy printing without using a computer.

# Contents

## Chapter 1 Quick Guide

<b>Before Shooting</b> .....	<b>10</b>
Packing List.....	10
Optional Accessories.....	11
About Options for GR DIGITAL Only.....	12
Accessories.....	13
Names of parts.....	14
Using the Mode Dial.....	16
Up-down Dial/ADJ. Dial.....	16
About LCD Monitor Display.....	17
<b>Getting Ready to Shoot</b> .....	<b>19</b>
About the Batteries.....	19
Batteries (Cells) Not Acceptable.....	20
Battery level indication.....	21
About an SD Memory Card (available in stores).....	22
Inserting an SD Memory Card.....	23
Charging the Rechargeable Battery.....	24
Inserting the rechargeable battery.....	25
Using the AC Adapter (sold separately).....	26
Loading the Batteries.....	28
Turning the Power On/Off.....	29
Setting the language.....	30
Setting the date and time.....	31
Changing the Display.....	32
Maximizing the LCD Monitor Brightness.....	32
Histogram Display.....	33
<b>Basic Shooting</b> .....	<b>34</b>
How to Hold the Camera.....	34
Preventing camera shake.....	35
Capturing the Moment Shooting (Full-press).....	36
Checking the Focus and Shooting (Half-press).....	37
When the Subject is not Centered (Shooting with Focus-lock).....	40
Using the Digital Zoom.....	42
Shooting Close-Ups (Macro-Mode).....	43
Using the Flash.....	44
Using the Hot Shoe.....	45
Shooting with Scenery-Matching.....	47
<b>Playing Back</b> .....	<b>48</b>
Checking the image you just took (Quick Review).....	48
Viewing Your Images.....	49
Playing back in the three-frame view.....	50
Thumbnail Display.....	52
Magnifying Images.....	53
<b>Viewing on a Television</b> .....	<b>54</b>
<b>Erasing</b> .....	<b>56</b>
Erasing Unwanted Files (Still Images/Movies/Sounds).....	56
Erasing Multiple Frames at One Time.....	57

## **Chapter 2      A Variety of Shooting Techniques/Playback**

<b>Direct Printing</b> .....	<b>60</b>
Direct Print Function .....	60
Connecting the Camera to a Printer .....	60
Printing Still Images .....	61
<b>A Variety of Shooting Techniques</b> .....	<b>65</b>
Using the ADJ. (Adjust) Mode .....	65
Shooting Setting Menu .....	67
Using the Shooting Setting Menu .....	68
Choosing Picture Quality Mode/Image Size (PIC QUALITY/SIZE) .....	69
Changing the Focusing Mode (FOCUS: MULTI AF/SPOT AF) .....	72
Manual Focus Shooting (FOCUS: MF) .....	74
Shooting at a Fixed Distance (FOCUS: SNAP/ ∞ ) .....	76
Changing the Light Metering (PHOTOMETRY) .....	77
Setting the Image Quality (IMG SET) .....	78
Shooting Consecutively with Different Exposures (AUTO BRACKET) .....	80
Shooting Consecutively with Different White Balance (WHITE BALANCE BRACKET) .....	81
Shooting Pictures Automatically at Set Intervals (INTERVAL) .....	83
Shooting a Still Image with Sound (IMAGE WITH SOUND) .....	85
Inserting the Date into a Still Image (DATE IMPRINT) .....	86
Changing the Exposure (EXPOSURE COMP.) .....	87
Using Natural and Artificial Lighting (WHITE BALANCE) .....	88
Changing Sensitivities (ISO SETTING) .....	91
Returning the Shooting Setting Menu Settings to their Defaults (RESTORE DEFAULTS) .....	92
Changing Shading for Shooting Text (DENSITY) .....	93
Using the AF Target Shift Function .....	94
Using the Self-Timer .....	95
Shooting with the Aperture Set (Aperture Priority Mode) .....	96
Shooting with the Aperture and Shutter Speed Set (Manual Exposure Mode) .....	97
Shooting with the Aperture and Shutter Speed Changed (Program Shift Mode) .....	99
<b>Shooting with Multi-Shot</b> .....	<b>101</b>
CONT .....	103
SCONT (S Multi-Shot) .....	103
MCONT (M Multi-Shot) .....	103
Viewing an S Multi-Shot or M Multi-Shot Still Image in Enlarged Display Mode .....	104
<b>Shooting/Playing Back Movies</b> .....	<b>105</b>
Shooting Movies .....	105
Playing Back Movies .....	107
<b>Recording/Playing Back Sound</b> .....	<b>108</b>
Recording Sound .....	108
Playing Back Sound .....	109
<b>Other Functions Available in Playback Mode</b> .....	<b>110</b>
Playback Setting Menu .....	110
Using the Playback Menu .....	110
Showing Photos in Order Automatically (SLIDE SHOW) .....	111
Write-protecting Your Images (PROTECT) .....	112
Using a Printing Service (DPOF) .....	115
Changing the Image Size (RESIZE) .....	118
Copying the Contents of Internal Memory to a Memory Card (COPY TO CARD) .....	119



## Chapter 3 Changing Camera Settings

---

<b>Changing Camera Settings</b> .....	<b>122</b>
SETUP Menu .....	122
Using the SETUP Menu .....	123
Formatting the SD Memory Card (FORMAT [CARD]).....	124
Formatting Internal Memory (FORMAT [INT. MEM.] ) .....	125
Adjusting the Brightness of the LCD Monitor (LCD BRIGHTNESS) .....	126
Setting a Function to the ADJ. dial (ADJ BTN.SET. 1/2).....	127
Changing Auto Power-Off Settings (AUTO POWER OFF) .....	128
Changing the Beep Sound Setting (BEEP SOUND) .....	129
Changing the Beep Sound Volume (VOL. SETTINGS) .....	130
Changing Image Confirmation Time (LCD CONFIRM.) .....	131
Changing File Name Settings (SEQUENTIAL NO.) .....	132
Setting the Date and Time (DATE SETTINGS).....	134
Changing the Display Language (LANGUAGE/ 言語 ) .....	135
Changing the Playback Method for Viewing on TV (VIDEO OUT MODE).....	136
Displaying a Setting Change Warning (SHTG STGS WARNG.).....	137
Changing the USB Communication System (USB Connection).....	138
Enlarging Icon Display (ENLGE PHOTO ICON) .....	142
Setting the Color Space (COLOR SPACE SET) .....	143
Setting the AF Auxiliary Light (AF AUX. LIGHT) .....	145
Setting Whether to Use Digital Zooming (DIGITAL ZOOM) .....	146
Changing the Zoom Button Setting (ZOOM BTN. SET.).....	147
Registering the Power-on Settings (REG. MY SETTINGS) .....	148
Changing the Startup Settings (START SETTING).....	149

## Chapter 4 Installing Software

---

<b>Installing the Provided Software (For Windows)</b> .....	<b>152</b>
System Requirements for Using the Provided Software .....	156
Installing the Software on Your Computer.....	157
Installing the DeskTopBinder Lite.....	159
Connecting the Camera to Your Computer .....	161
Downloading Images from an SD Memory Card .....	166
Installing Acrobat Reader .....	167
Installing DirectX .....	168
Uninstalling the Software.....	169
Uninstalling the ImageMixer .....	170
<b>Installing the Provided Software (For Macintosh)</b> .....	<b>171</b>
System Requirements for Using the Provided Software .....	173
Installing the Software on Your Computer (Mac OS 8.6 to 9.2.2) .....	174
Installing the Software on Your Computer (Mac OS X 10.1.2 to 10.4).....	175
Installing Adobe® Photoshop® Elements (Trial Version).....	177

## Chapter 5 Troubleshooting

---





<b>Troubleshooting</b> .....	<b>180</b>
Troubleshooting the Camera.....	180
Warning Messages Under Windows XP Service Pack 2 .....	185
<b>Appendices</b> .....	<b>187</b>
A. Specifications .....	187
B. Recommended Parts .....	189
C. Menu Items By Mode.....	190



D. Functions Whose Defaults will be Restored upon Power-off .....	190
E. Number of Images That Can be Stored in Internal Memory/SD Memory Card .....	192
F. Operations that can be Performed with the Up-down Dial and ADJ. Dial .....	193
G. Using Your Camera Abroad .....	194
H. Cautions on Use .....	195
I. Care and Storage .....	196
J. Error Messages .....	197
K. Warranty and Servicing .....	198
Index .....	200

## Using Manuals

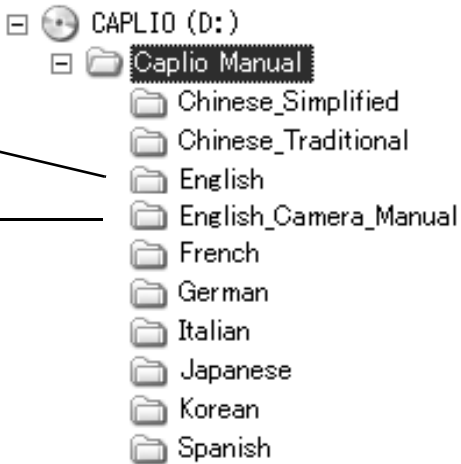
The two manuals included are for your GR DIGITAL.

	<h3>Camera User Guide (This booklet)</h3>
	<p>This guide explains the usage and functions of the camera. You will also see how to install the provided software on your computer.          *The Software User Guide (English edition) is available from the provided CD-ROM as a PDF file.</p>
	<h3>Software User Guide (PDF file)</h3>
	<p>This guide explains how to download images from the camera to your computer, and display and edit them on your computer.          *The Software User Guide is available from the following folder on the provided CD-ROM.</p>
	<p>Windows</p> <p>Each language has its own Software User Guide in the respective folder.</p> <p>"Software User Guide (English edition)" (PDF file)</p> <div style="margin-left: 400px;">  </div>
	<p>Macintosh</p> <p>Each language has its own Software User Guide in the respective folder.</p> <div style="margin-left: 400px;">  </div>

## To copy the Software User Guide onto your hard disk

Copy the PDF file from the above folder.

## Reference

---

The camera is provided with software (ImageMixer) that allows you to display and edit images from your computer. For how to use ImageMixer, click the [?] button on the ImageMixer window and see the displayed manual.

For more information on the ImageMixer, contact the Customer Support Center below.

North America (Los Angeles) TEL: +1-213-341-0163  
Europe (U.K.) TEL: +44-1489-564-764  
Asia (Philippines) TEL: +63-2-438-0090  
China TEL: +86-21-5450-0391  
Registration time: 9:00 - 17:00





## How to Use This Guide

---

Chapter 1 explains the basic operations of this product.

If you are using the camera for the first time, read from this chapter.

The following symbols are also used in this guide:

 Important	This indicates important notices and restrictions for using this camera.
 Note	This indicates supplementary explanations and useful tips about camera operations.
 Term	This indicates terms that are useful for understanding the explanations.
 Reference	This indicates page(s) relevant to a particular function.

The LCD Monitor Display examples may be different from actual display screens.

# Chapter 1

## Quick Guide

If you are using the camera for the first time, read from this chapter.

<b>Before Shooting</b> .....	<b>10</b>
<b>Getting Ready to Shoot</b> .....	<b>19</b>
<b>Basic Shooting</b> .....	<b>34</b>
<b>Playing Back</b> .....	<b>48</b>
<b>Viewing on a Television</b> .....	<b>54</b>
<b>Erasing</b> .....	<b>56</b>

# Before Shooting

## Packing List

---

Open the package and make sure all the items are included.

- GR DIGITAL

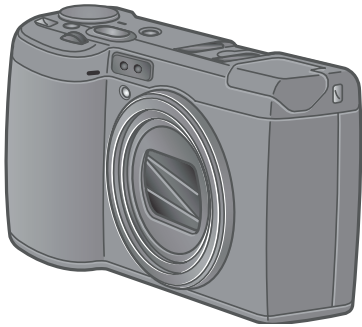

- Rechargeable Battery

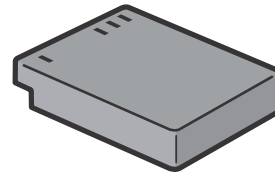

- AV Cable

Used when viewing your images on a TV unit.

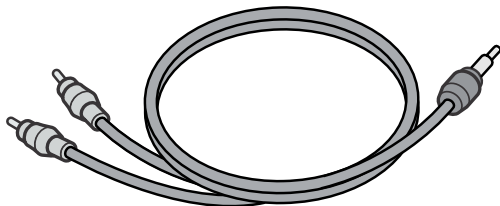

- Battery Charger

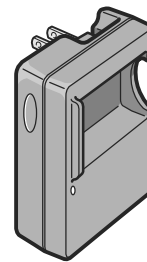

- USB Cable

Used to connect the camera to a computer or Direct Print supported printer.

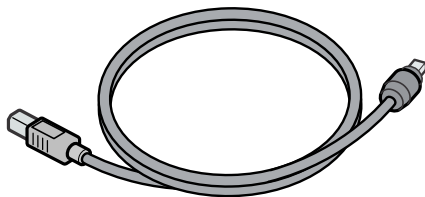

- Handstrap

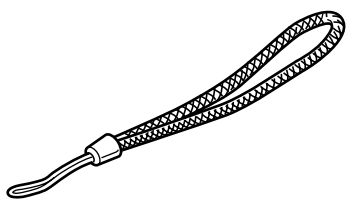

### Note

---

#### Attaching the hand strap to the camera

Thread the tips of the strap through the camera's strap eyelet and loop them as shown.

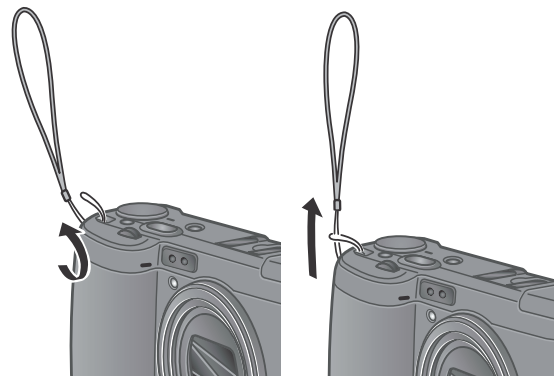

The serial number of this product is given on the bottom face of the camera.

- Camera User Guide (This booklet)



- Warranty

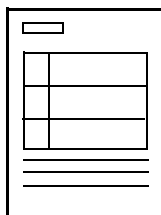

- Safety Precautions



- Caplio Software CD-ROM  
The provided software and the Software User Guide are included on this CD-ROM.



- Adobe Photoshop Elements (Trial Version) CD-ROM

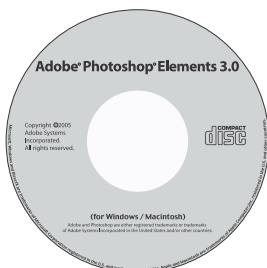

## Optional Accessories

- Cable switch (CA-1)

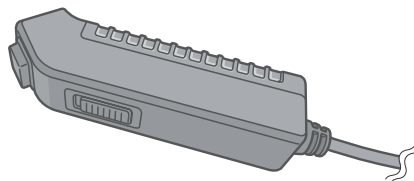

- AC Adapter (AC-4c)

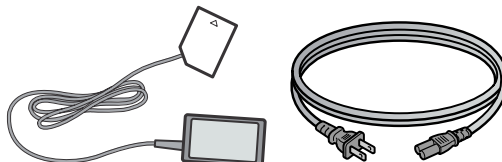

- Rechargeable Battery (DB-60)

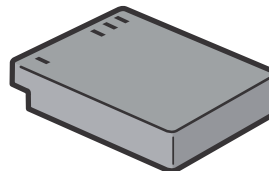

- Battery Charger (BJ-6)

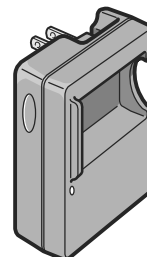

- PC Card Adapter (FM-SD53)
- SD Memory Card (available in stores)



### Reference

For the latest information about accessories, access Ricoh home page (<http://www.ricohpmmc.com>).

## About Options for GR DIGITAL Only

---

- Wide conversion lens (GW-1)

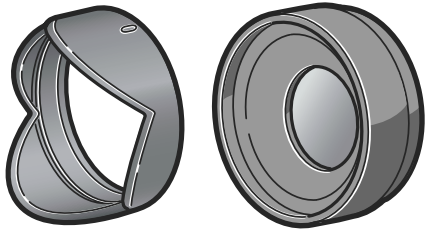

This lens has a magnification of x0.75 that is equivalent to 21 mm (as converted to be equivalent to 35 mm).

The hood & adapter (with case) is used in combination.

- Hood & adapter (GH-1)

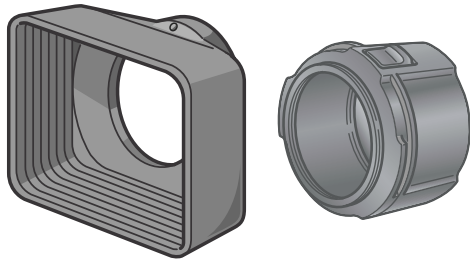

This is a set of a hood to prevent lens exposure to sunlight and an adapter used to attach a  $\phi$  37 mm general-purpose filter.

- External Viewfinder (GV-1)

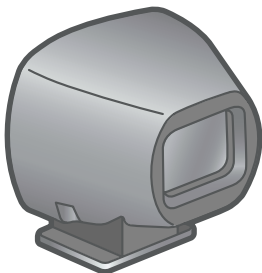

This optical viewfinder is to be attached to the hot shoe.

This viewfinder has a frame for 21 mm and 28 mm (as converted to be equivalent to 35 mm) (with case).

- Soft Case (GC-1)

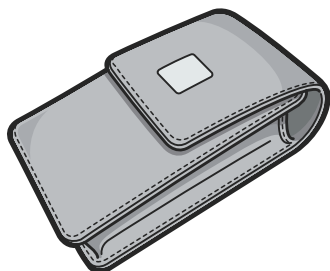

- Neck strap (GS-1)

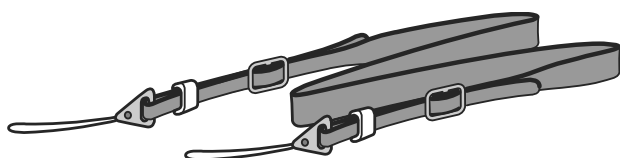

# Accessories

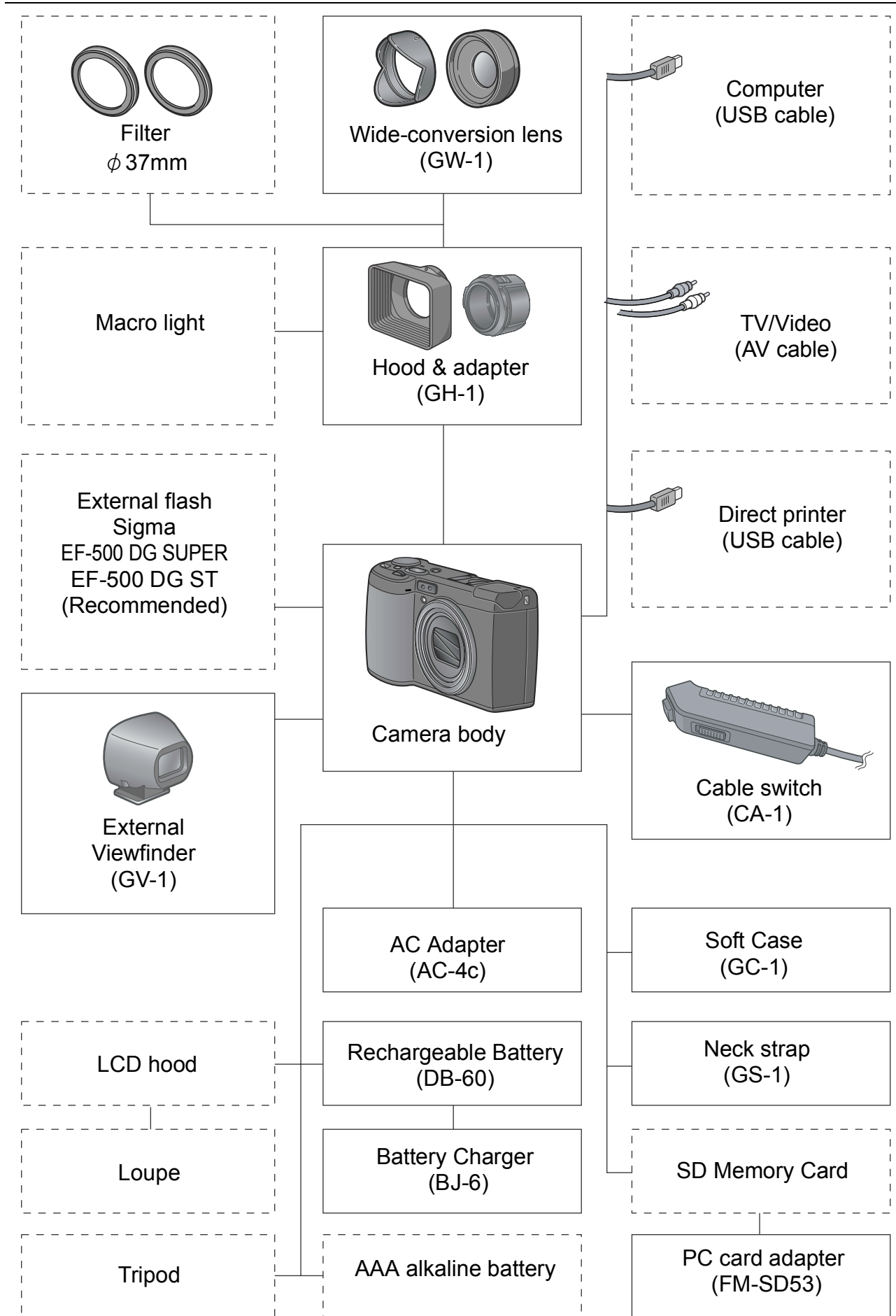

Optional item

General-purpose item



# Names of parts

## Camera

### Front View

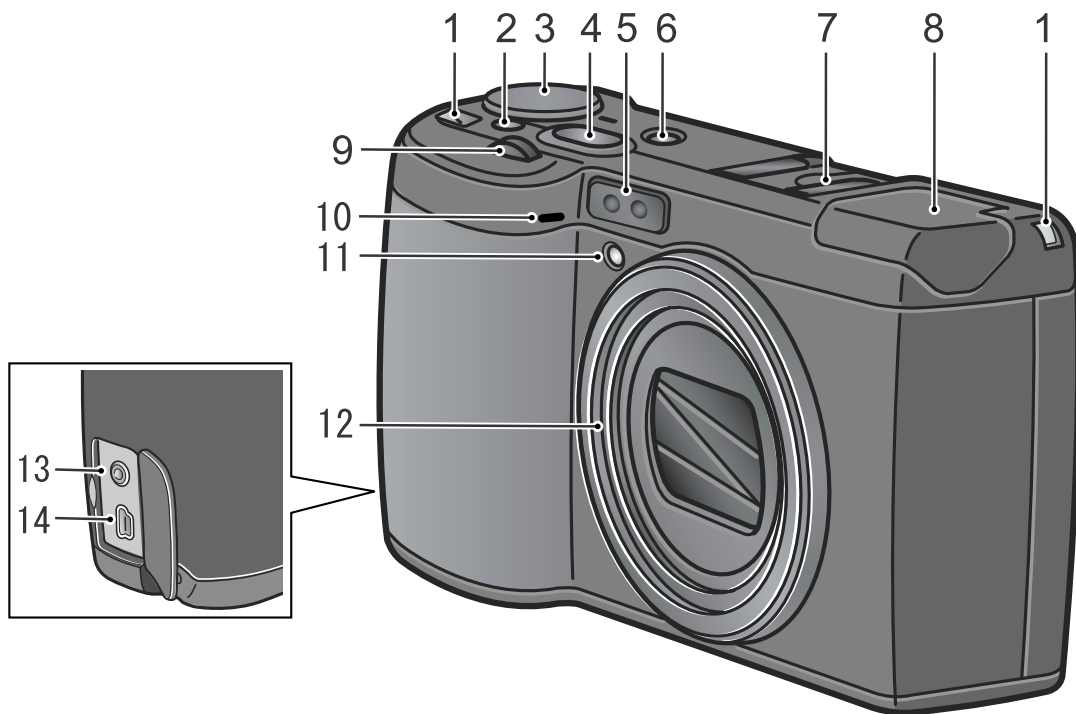

	Item Name	Refer to
1	Strap Eyelet	P.10
2	Unlock Button	P.16
3	Mode Dial	P.16
4	Shutter Release Button	P.34
5	AF Window	-
6	Power Button	P.29
7	Hot Shoe	P.45
8	Flash	P.44
9	Up-down Dial	P.16
10	Microphone	P.108
11	AF Auxiliary Light	P.145
12	Lens	P.34
13	AV-Out Terminal	P.54
14	USB Terminal	P.161

### **Caution**

To avoid damaging the connectors, do not plug any objects into the camera's microphone or speaker holes.

# Rear View

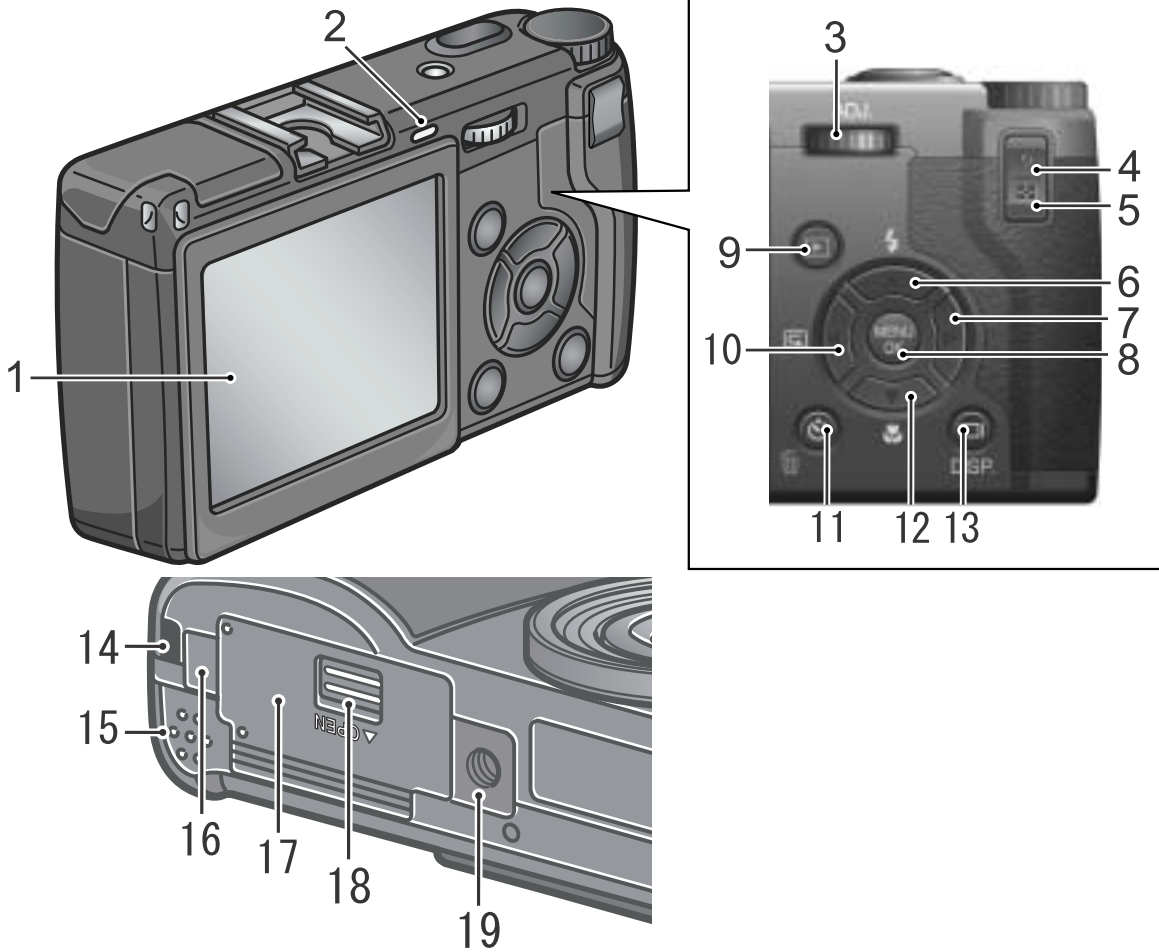

	Item Name	Refer to		Item Name	Refer to
1	LCD Monitor	-	11	(Delete) /  (Self-timer) Button	P.56 P.95
2	Auto Focus/ Flash Lamp	P.37 P.44	12	(Macro) Button	P.43
3	ADJ. Dial	P.65	13	(DISP.) Button	P.32
4	(Enlarged View) Button	P.42 P.53 P.147	14	Strap Eyelet	P.10
5	(Thumbnail Display) Button	P.42 P.52 P.147	15	Speaker	P.107 P.109
6	(Flash) Button	P.44	16	Power (DC in) Cable Cover	P.26
7	Button	-	17	Battery/Card Cover	-
8	MENU/OK Button	P.68 P.110	18	Release lever	P.23 P.25 P.28
9	(Playback) Button	P.49	19	Tripod Screw Hole (underside)	-
10	(Quick Review) Button	P.48			



# Using the Mode Dial

The Mode Dial is provided on top of the camera. Turn the Mode Dial to select the camera operation mode such as shooting, playback (still image display), or setting change.

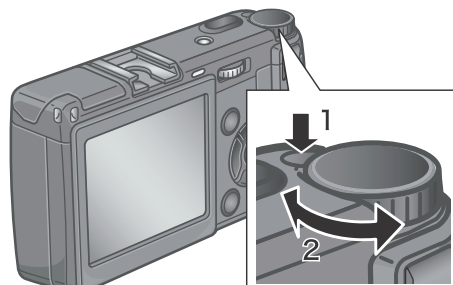
1. Hold down the **Unlock** button while turning the **Mode Dial** to the mark of your desired mode.



## Mode Dial Symbols and Functions

Symbol	Mode Name	Function	Refer to
<b>SCENE</b>	Scene mode	Use this to record sounds or to shoot text.	P.47
<b>M</b>	Manual Exposure mode	Use this to set the shutter speed and aperture manually.	P.97
<b>A</b>	Aperture Priority mode	Use this to set the aperture manually. The camera automatically sets the shutter speed corresponding to the manually set aperture.	P.96
<b>P</b>	Program Shift mode	Use this to change the combination of aperture and shutter speed.	P.99
	Still Image mode	Use this to shoot still images.	P.36
	Movie mode	Use this to shoot movies.	P.105

## Up-down Dial/ADJ. Dial

The up-down dial and ADJ. dial allow you to perform various operations easily together with the **▲▼◀▶** buttons. Turn the up-down and ADJ. dials as shown.

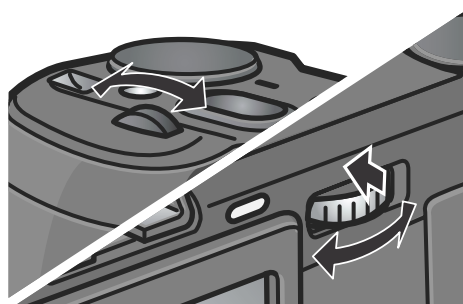

### Reference

For the operations possible with the up-down and ADJ. dials, see P.193.

# About LCD Monitor Display

## Screen Examples when Shooting Pictures

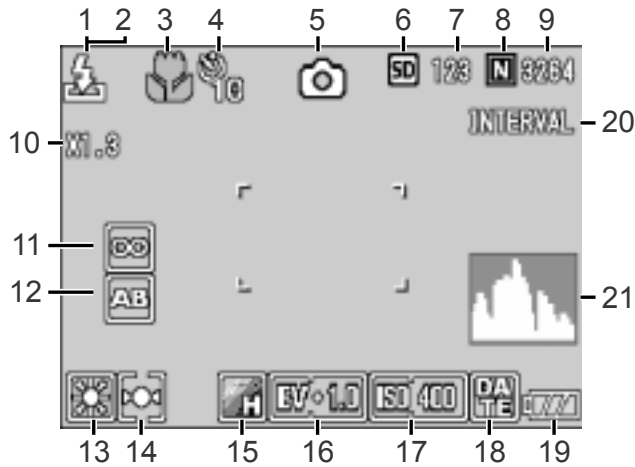

(When the shutter release button is half-pressed)

Still Image Mode

Movie Mode

	Item Name	Refer to		Item Name	Refer to
1	Flash	P.44	14	Photometry	P.77
2	External flash	P.45	15	Image Setting	P.78
3	Macro Shooting	P.43	16	Exposure	P.87
4	Self-timer	P.95	17	ISO Setting	P.91
5	Mode Types	-	18	Date/Time	P.86
6	Recording Destination	P.22	19	Battery	P.19
7	Remaining Number of Still Images	P.192	20	Interval	P.83
8	Picture Quality	P.69	21	Histogram	P.33
9	Image Size	P.69	22	Camera Shake	P.35
10	Digital zoom	P.42	23	Aperture Value	P.37
11	Focus	P.72	24	Shutter Speed	P.37
12	Auto Bracket	P.80	25	Remaining Recording Time	P.192
13	White Balance	P.88	26	Recording Time	P.192

 **Note**

- The number of remaining shots available may differ from the actual number of shots, depending on the subject.
- Even between cards of the same capacity, the number of remaining shots and other values may vary with the manufacturer, type, and shooting condition.
- The continuous shooting (recording) time depends on the card type, capacity, and performance.
- When the number of remaining shots is 10,000 or more, "9999" is displayed.

## The Screen During Playback

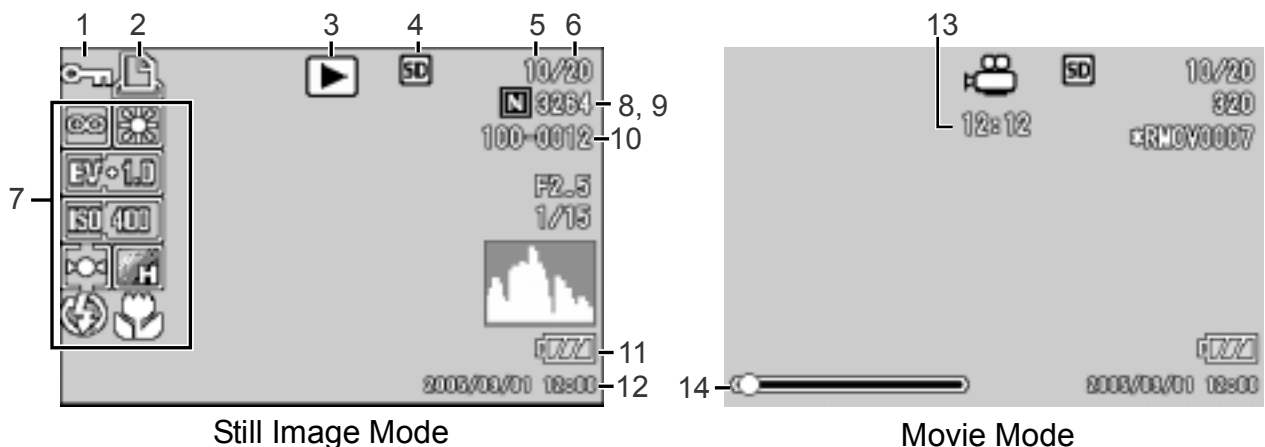

Item Name	Refer to	Item Name	Refer to
1 Protect	P.112	8 Picture Quality	P.69
2 DPOF	P.115	9 Image Size	P.69
3 Mode Types	-	10 File No.	-
4 Playback Data Source	P.49	11 Battery	P.19
5 Number of Playback Files	-	12 Date at Shooting	P.86 P.134
6 Total Number of Files	-	13 Recording Time or Lapsed Time	-
7 Setting at Shooting (Recording)	-	14 Indicator	-

 **Note**

The LCD monitor may display messages to inform you of operational instructions or the camera's status while in use.

# Getting Ready to Shoot

Turn the power on and get ready to shoot.

## Note

If you have already used this camera, follow the steps below to make sure it is turned off before removing or loading batteries.

1. Make sure the LCD monitor is turned off.
2. Make sure the protective lens barrier is closed.

For how to turn the camera off, see P.29.

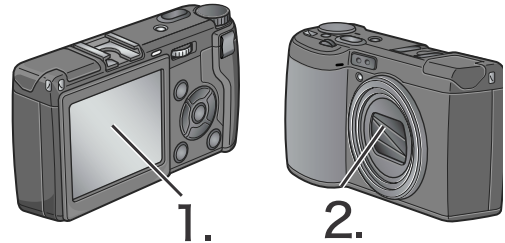

## About the Batteries

The following batteries can be used in the camera. Please choose which kind to use according to your needs.

### • Rechargeable Battery DB-60

This is a lithium-ion battery. This is economical because you can recharge it using the battery charger and use it over and over again. They last a long time, so they are convenient for travel.

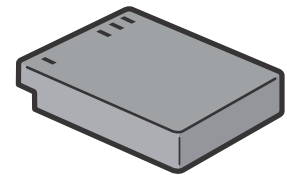

### • AAA alkaline batteries (available in stores)

You can obtain them anywhere, so they are convenient for travel.

However, in a low-temperature environment the number of shots you can take will decrease.

Warm the batteries before use. It is recommended that you use the rechargeable battery when using the camera for a long time.

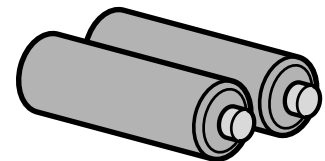

### • AAA Oxymide batteries (available in stores)

Oxymide batteries cannot be recharged.

However, they last long as compared with AAA alkaline batteries.

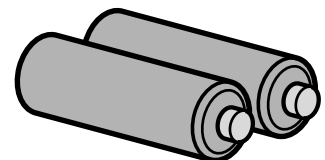

- **AAA nickel hydride batteries (available in stores)**

This is economical because you can recharge and use it over and over again. Use a charger (available in stores) for charging.

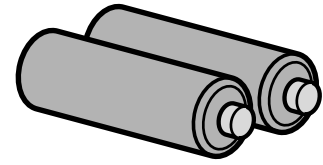

The battery may be inert and consequently it may not supply power immediately after it is purchased or left unused for more than a month. In such a case, recharge the battery two or three times before use. The battery self-discharges with time even if the camera is not used, so recharge it before use.

In addition to the batteries, you can use the AC Adapter.

## **Batteries (Cells) Not Acceptable**

---

The camera does not accept the following batteries (cells):

- Manganese dry cell (R03)
- Ni-Cd battery



### **Note**

---

#### **Indication of the number of images you can take**

Battery Type	Number of Shots
Rechargeable Battery (DB-60)	Approx. 250
AAA alkaline batteries	Approx. 30

- Based on CIPA standard (Temperature: 23 degrees Celsius, LCD on, 50% flash usage, turning the power off after each 10 shots).
- Number of shots of the AAA Alkaline Batteries, it is using the AAA Alkaline Batteries by Matsushita Battery Industrial Co., Ltd.
- If you set the camera to the Power-Save or Synchro-Monitor mode, the number of shots you can take will increase. (P.32)
- The number of shots is for reference only. If the camera is used for long periods of time for setting and playback, the shooting time (the number of shots) will decrease.



### **Reference**

---

- For how to insert the Rechargeable Battery, see P.25.
- For how to use the AC Adapter, see P.26.





## Caution





- Please remove the batteries if you are not going to use the camera for a long period of time.
- The life of an AAA alkaline battery depends on the brand and the storage time from the date of production. In addition, the life of an AAA alkaline battery becomes shorter at low temperatures.
- The AAA Nickel-Hydrogen Battery is not factory-charged. Charge it before use. Immediately after the purchase or after a long storage, the battery may not be charged fully. Repeat charging and discharging before use. For details, see the documentation that came with the battery or charger.
- The battery may become very hot immediately after operation. Turn the camera off and leave it to cool down sufficiently before removing the battery.

## Battery level indication

A battery mark appears at the lower left of the LCD monitor to indicate the battery level. Prepare new batteries before the batteries wear out.

Battery Mark	Description
 Green	Sufficient battery charge
 Green	Low remaining charge: Prepare new batteries.
 Orange	No remaining charge: Replace the batteries.

## Caution

- If you are using nickel metal hydride batteries,  may not appear or  or  may appear immediately depending on the battery type and environmental conditions. Check the batteries at hand before use.
- If you are using the AC Adapter,  may appear. This does not indicate malfunction and you can continue to use the camera.

# About an SD Memory Card (available in stores)

You can store still images you have taken either in the camera's internal memory or on an SD Memory Card (available in stores). The internal memory capacity is 26 MB.

When you want to record a lot of still images, movies or sounds at high resolutions, use a high-capacity SD Memory Card.

## Note

### Where images are recorded

When no SD memory card is inserted, the camera records images in the internal memory; when an SD memory card is inserted, it records images on the memory card.

When no memory card is loaded	Records to internal memory
When an SD Memory Card is loaded	Records to the SD memory card

## Caution

- If an SD memory card is loaded, the camera will not record to the internal memory, even if the card is full.
- Take care not to get the metal parts of the card dirty.
- Before using a new SD memory card, be sure to format it.

## Note

### Write-protecting your images

If you move the card's write-protection switch to LOCK, your still images cannot be accidentally erased and the memory card cannot be formatted. If you release the protection (by returning the switch to its original position), it is once again possible to erase images and format the card.

So it's a good idea to switch to LOCK when you have some important data recorded.

Note that you cannot shoot images in the LOCK state because no data can be recorded on the card. Unlock the card when shooting.

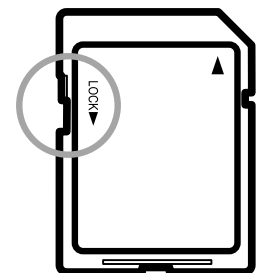

## Reference

- For switching between the SD Memory Card and internal memory during playback, see P.49.
- For recording capacities, see P.192.
- For how to format the SD memory card, see P.124.

# Inserting an SD Memory Card

If you have already used this camera, make sure it is turned off before loading an SD memory card.

**1. Slide the release lever to the OPEN side to open the battery/card cover.**

**2. Make sure the card is facing the right way and push the card all the way in until it clicks.**

**3. Close the battery/card cover and slide the release lever to the side opposite to OPEN to lock the cover.**

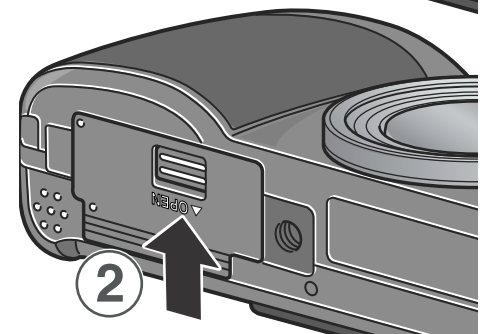
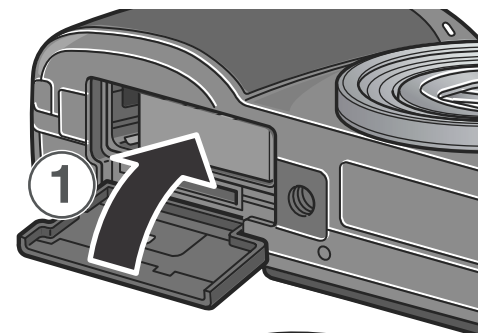
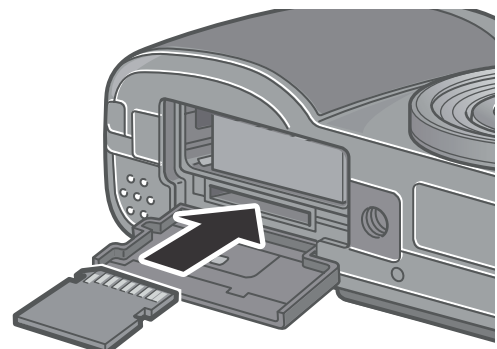
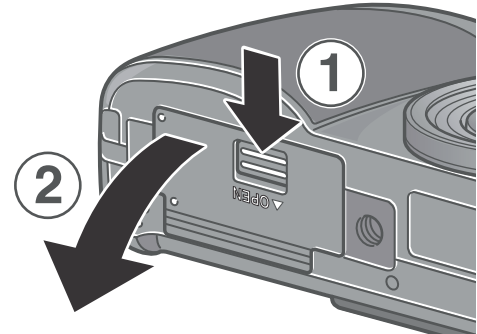

## Caution

Slide the release lever securely to lock the battery/card cover.

## Reference

For how to format the SD memory card, see P.124.

# Charging the Rechargeable Battery

The rechargeable battery needs to be charged before use.

- 1. Insert the battery, making sure that the  $\oplus$  and  $\ominus$  markings on the battery match with those on the battery charger.**

The battery label should face up.

## Caution

Be careful not to reverse the  $\oplus$  and  $\ominus$  sides.

- 2. Plug the battery charger into an outlet.**

Charging starts and the charger lamp shows you the progress as shown below. Once charging has finished, unplug the power cable from the power outlet.

Depending on the battery level, the charging time differs:

Charger Lamp	Description
Lit	Charging started
Unlit	Charging complete
Flashing	Battery charger or battery may be faulty (unplug the battery charger from the power outlet and remove the battery from the battery charger).

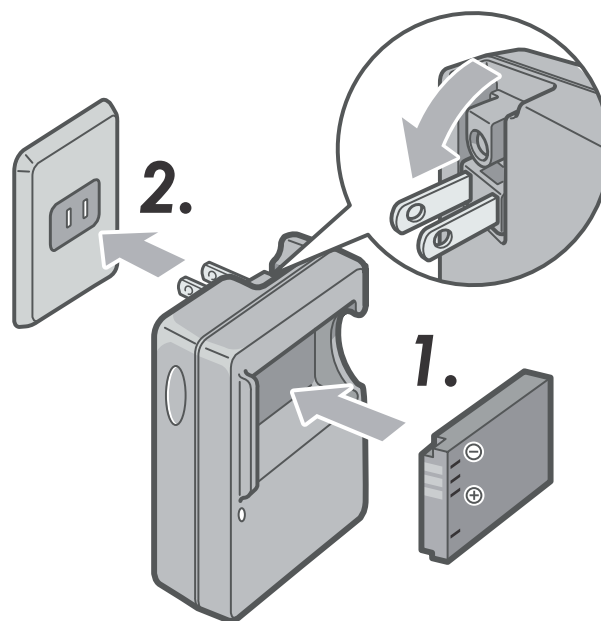

# Inserting the rechargeable battery

The rechargeable battery (DB-60) is another option for powering this camera. This battery is convenient because it can be used over and over again by recharging, and the battery power lasts long. If you have already used this camera, make sure it is turned off before loading batteries.

**1. Slide the release lever to the OPEN side to open the battery/card cover.**

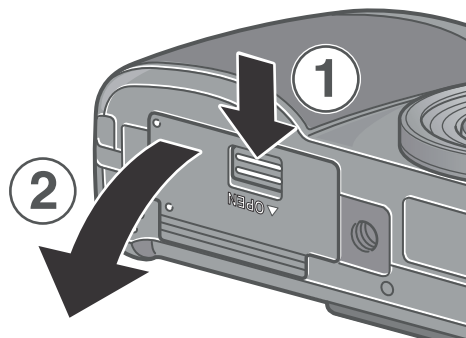

**2. Insert the rechargeable battery.**

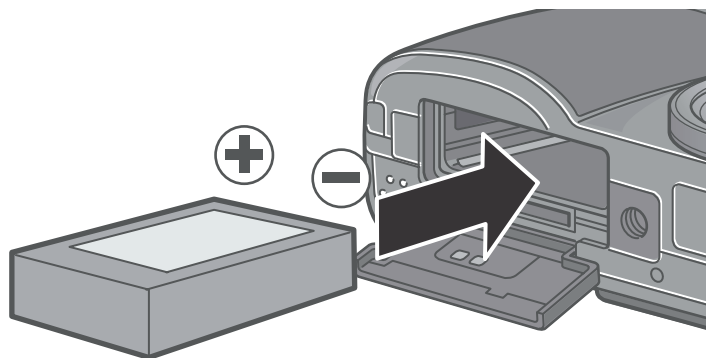

**3. Close the battery/card cover and slide the release lever to the side opposite to OPEN to lock the cover.**

## Caution

- Slide the release lever securely to lock the battery/card cover.
- Please remove the rechargeable batteries if you are not going to use the camera for a long period of time.
- Store the removed battery in a dry cool place.
- Use the battery charger to recharge the battery.

### Rechargeable battery charging time

DB-60	About two hours (25°C)
-------	------------------------

## Removing the rechargeable battery

If you have already used this camera, make sure it is turned off before removing batteries.

1. **Slide the release lever to the OPEN side to open the battery/card cover.**
2. **Remove the battery.**
3. **Close the battery/card cover and slide the release lever to the side opposite to OPEN to lock the cover.**

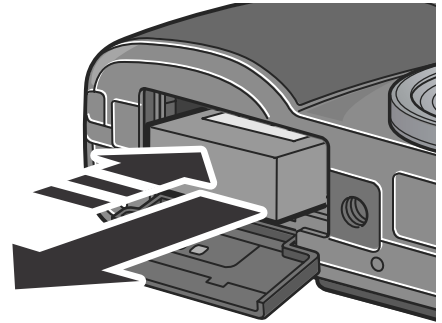

### Caution

Store the removed battery in a dry cool place.

## Using the AC Adapter (sold separately)

When shooting or viewing still images for a long time, or when connecting to your computer, using the AC Adapter (sold separately) is recommended.

If you have already used this camera, make sure it is turned off before loading the AC Adapter Battery.

1. **Slide the release lever to the OPEN side to open the battery/card cover.**
2. **Insert the AC Adapter Battery.**
3. **Open the power (DC input) cable cover and take the cable out.**

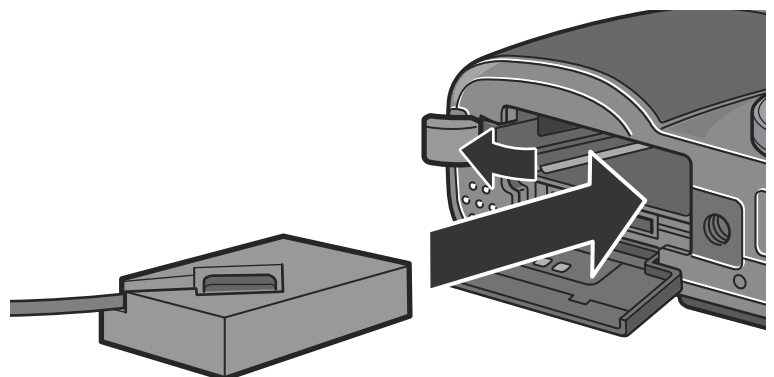

4. Close the battery/card cover and slide the release lever to the side opposite to OPEN to lock the cover.
5. Plug the power cord into an outlet.

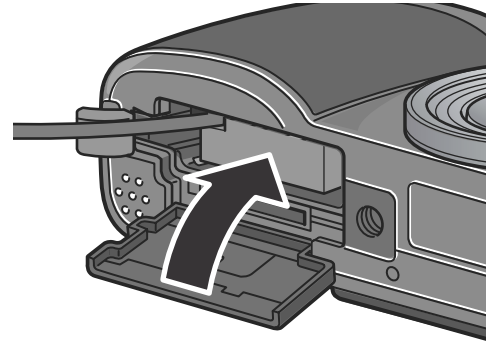

## Removing the AC Adapter

If you have already used this camera, make sure it is turned off before removing the AC Adapter Battery.

1. Unplug the power plug from the outlet.
2. Slide the release lever to the OPEN side to open the battery/card cover.
3. Remove the battery.
4. Close the battery/card cover and slide the release lever to the side opposite to OPEN to lock the cover.

### Caution

- Slide the release lever securely to lock the battery/card cover.
- Be sure to firmly attach cables and plug in cords.
- When you are not using the camera, unplug the AC Adapter from the camera and the power outlet.
- While in use, if you detach the AC Adapter or unplug it from the outlet, data may be lost.
- When using the AC Adapter, the battery level indication may not reach the full area.



# Loading the Batteries

If you have already used this camera, make sure it is turned off before loading batteries.

1. Slide the release lever to the **OPEN** side to open the battery/card cover.

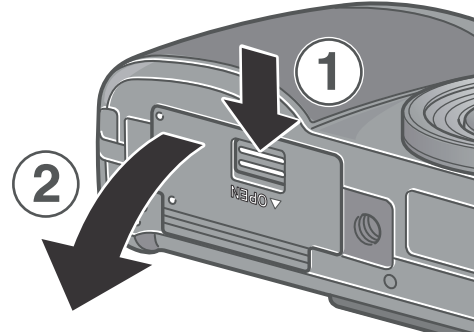

2. Insert the two batteries, making sure they are facing the correct way.

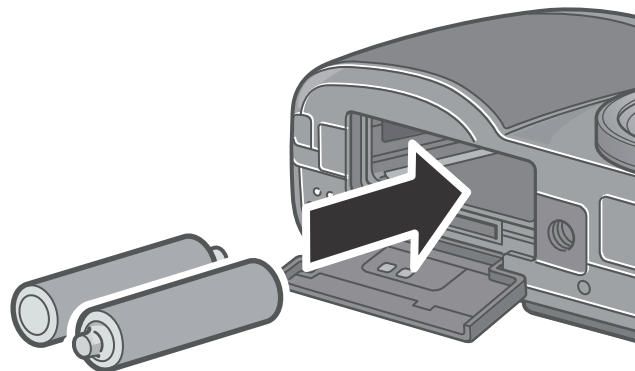

3. Close the battery/card cover and slide the release lever to the side opposite to **OPEN** to lock the cover.

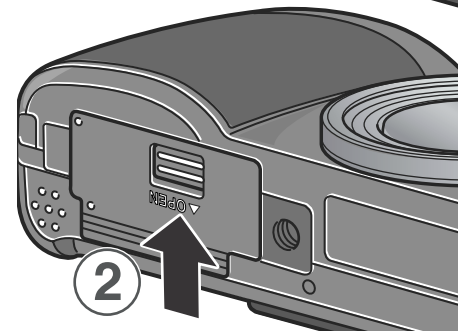
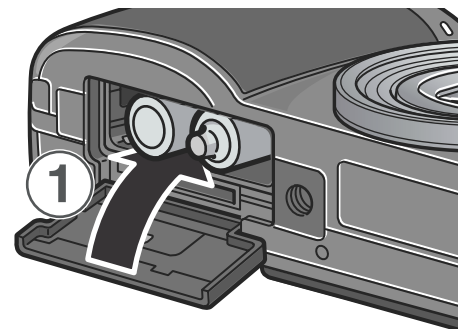

## Caution

Slide the release lever securely to lock the battery/card cover.

# Turning the Power On/Off

---

To turn the power on:

## 1. Press the Power button.

After the start sound, the auto-focus/flash lamp blinks for several seconds.



## Using the Camera in Playback Mode

Pressing the Playback button for more than one second turns on the camera in Playback Mode, allowing you to start playback at once.

To turn the power off:

## 1. Press the Power button.

### Caution

---

- If you have turned on the camera by pressing the Playback button, pressing the Playback button again allows you to select the Shooting Mode.
- It takes longer from power-on until the camera becomes ready for shooting when the flash is enabled than when it is disabled.

### Note

---

#### Auto Power Off

If the camera goes unused for a set period of time, it will automatically turn itself off to save power. To continue on using the camera, slide the power switch to close the lens cover once (power-off) and slide it again to open (power-on).

### Reference

---

For how to change the Auto Power Off setting, see P.128.

# Setting the language

---

When the power is turned on for the first time, the language setting screen appears (for the LCD monitor display language). After setting the language, go on to the date/time setting (for printing the date and time on your photos).

You can shoot without these settings. However, be sure to set the language, and the date/time later. Use the SETUP screen for these settings.



## Note

---

To display the SETUP screen, turn the mode dial to SETUP.

### 1. Turn the power on for the first time after purchase.

The language selection screen appears.

To skip language setting, press the MENU/OK button.

When the MENU/OK button is pressed, the language setting is cancelled and the video signal format-setting screen appears.

### 2. Press the ▲▼◀▶ buttons to select a language.

### 3. Press the MENU/OK button.

The display language is set, and the date/time setting screen appears.



## Reference

---

For how to set the display language and date/time on the SETUP screen, see "Changing the Display Language (LANGUAGE)" and "Setting the Date and Time (DATE SETTINGS)" in this guide.

# Setting the date and time

When the power is turned on for the first time and the language setting is completed, the date/time setting screen appears.

**1. Press the ▲▼◀▶ buttons to set the year, month, date and time.**

Change the value with ▲▼ and move the frame with ◀▶.

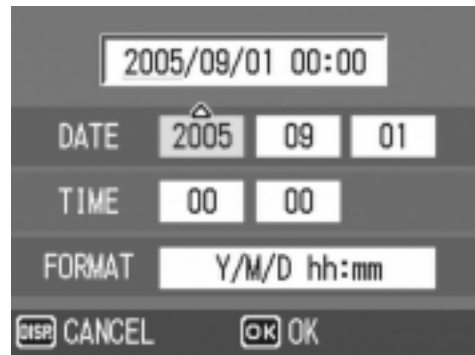

Setting at shipping

**2. In [FORMAT], choose the Date and Time format.**

Select the format with ▲▼.

**3. Check the display on the bottom of the screen and then press the MENU/OK button.**

The date is set.

Pressing the DISP. button on this screen allows you to cancel the setting.

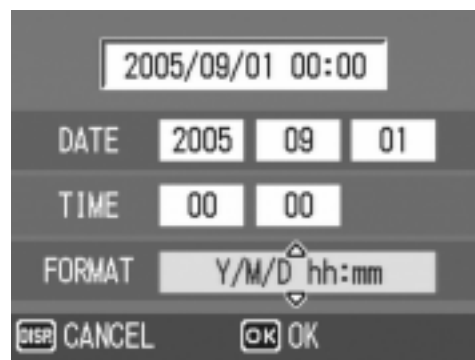

## Note

- If the batteries are removed for more than one week, the date and time settings will be lost. These settings must be made again.
- To retain the date and time settings, load a fully charged battery in the camera for more than two hours.

## Reference

- For how to correct the set date and time,, see P.134.
- For how to put a date stamp on each frame, see P.86.

## Changing the Display

---

If you press DISP., you can change the screen display mode, such as switching between display/no display of symbols, etc.

Every time you press the DISP. button, the view cycles in the order of Histogram On, Grid Guide, No Display, LCD Monitor Off, and Normal Symbol Display.

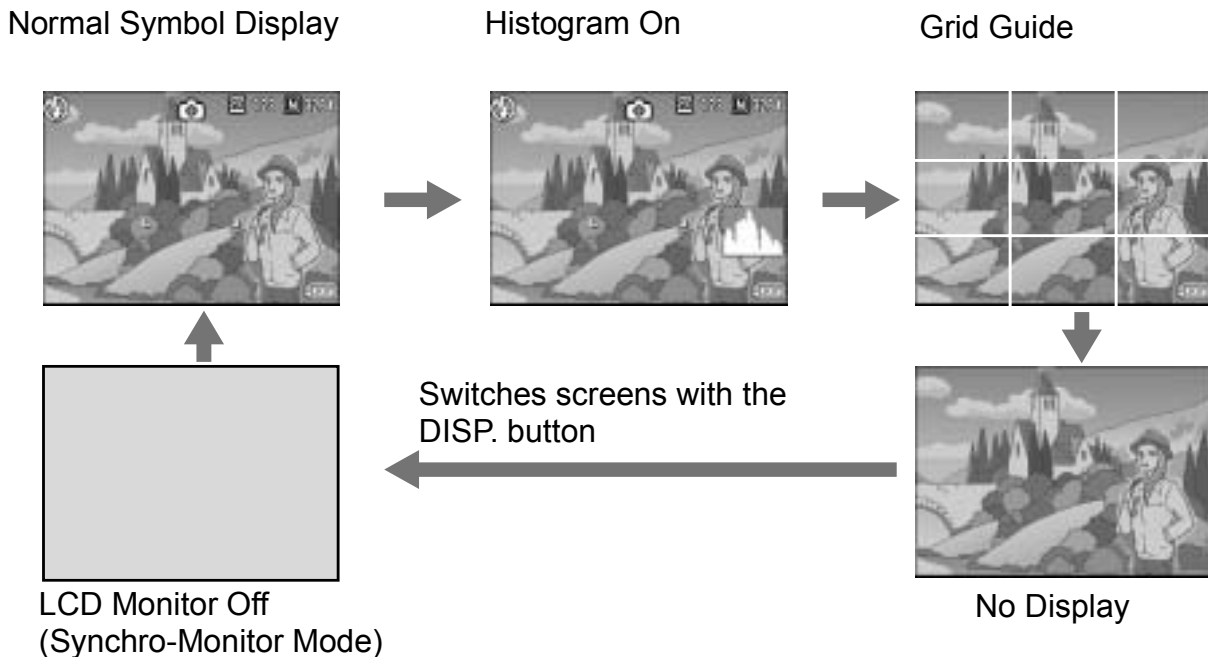

## Maximizing the LCD Monitor Brightness

---

Hold the DISP. button down to maximize the display brightness.

When the brightness is maximal, holding the DISP. button down returns the brightness to the level set in [LCD BRIGHTNESS] (P.126).

### Term

#### **Grid Guide**

Displays auxiliary lines on the LCD monitor to help shooting. These lines are not recorded with images.

#### **Synchro-Monitor Mode**

Keeps the LCD monitor off except when the camera is operated. This mode is effective for saving power consumption. With this mode, half-pressing the shutter release button turns the LCD monitor on. Subsequently, full-pressing the shutter release button displays the shot image on the LCD monitor, and then turns the LCD monitor off.

# Histogram Display

When histogram display is on, a histogram appears in the lower right corner on the LCD monitor screen.

A histogram is a graph indicating the number of pixels on the vertical axis and the brightness on the horizontal axis. The brightness is shadow (dark), halftone, and highlight (light) from the left.

By using the histogram, you can judge the brightness of an image without being affected by the brightness around the LCD monitor. This also helps preventing voids and solids.

If the histogram has only peaks on the right side without anything else, this picture is over-exposed with too many pixels only for highlight sections.



If the histogram has only peaks on the left side without anything else, this picture is under-exposed with too many pixels only for shadow sections.

Correct the exposure to an appropriate level.



## Note

- The histogram displayed on the LCD monitor is for reference only. Depending on the shooting condition (flashing is required, the surrounding light is dark, and so on), the exposure level indicated in the histogram may not correspond to the brightness of the shot image.
- Exposure compensation has its limitation. It does not necessarily achieve the best possible result.
- The histogram having peaks in the center part does not necessarily provide the best result to suit your particular requirements.  
For example, an adjustment is required if you want to intentionally achieve under or over exposure.

## Reference

For details about exposure correction, see P.87.

# Basic Shooting

Now you are ready. Let's shoot!

## How to Hold the Camera

---

Hold the camera as illustrated below for best results.

- 1. Hold the camera with both hands and lightly press both elbows against your body.**

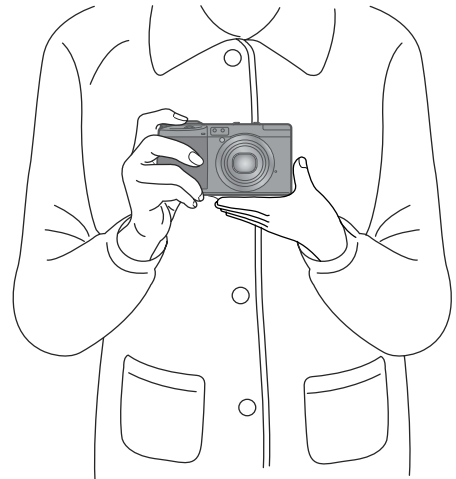

- 2. Put your finger on the shutter button.**

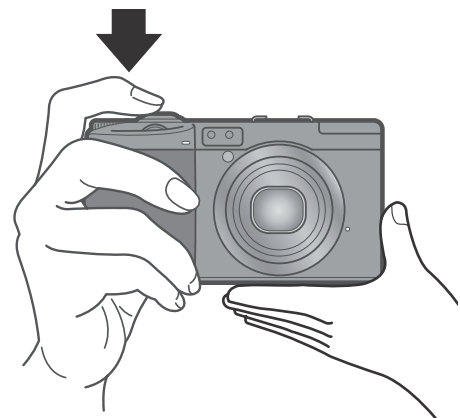

---

 **Note**

Be careful when you are shooting not to get a finger, your hair, or the strap in front of the lens or the flash.



## Preventing camera shake

---

If the camera moves when you press the shutter button, the still image might not come out clearly (due to camera shake). The  mark displayed on the LCD monitor indicates that camera shake should be avoided under the current shooting condition.

To prevent camera shake, use a tripod or hold the camera securely with both hands when you shoot.

Note that camera shake tends to occur in the following cases:

- When shooting in a dark place without using the flash.
- When shooting in Slow Sync Mode (P.44).
- When shooting using the Digital Zoom (P.42).

If the camera shake mark (  ) is displayed, try the following:

- Using the flash (Set the camera to Forced Flash Mode) (P.44).
- Raising the ISO sensitivity (P.91).
- Using the self-timer (P.95).

# Capturing the Moment Shooting (Full-press)

The shutter release button works in two steps.

There are two methods of using the shutter button; pressing the shutter button all the way down at once (full-press) and pressing it halfway (half-press).

Full-press the shutter release button for quick focusing not to miss a shooting opportunity.

1. **Make sure the camera power is on and turn the mode dial to , P, A, or M.**



2. **Compose your shot by looking at the LCD monitor.**



3. **Put the subject of your photo right in the middle and press the shutter release button fully.**

While the shot image is being written onto the card, the auto-focus/flash lamp blinks.



## Note

- The still image you have taken freezes for a moment on the LCD Monitor and is recorded. (P.131)
- Full-press is apt to cause camera shake. Hold the camera firmly with both hands and shoot.

# Checking the Focus and Shooting (Half-press)

When you press the shutter release button halfway (half-press), the autofocus function is triggered to determine the focal distance. Subsequently press it all the way down (full-press) to shoot.

This is useful when the subject is not in the middle (see P.40).

1. **Make sure the camera power is on and turn the mode dial to , P, A, or M.**



2. **Compose your shot by looking at the LCD monitor.**



3. **Put the subject of your photo right in the middle and press the shutter release button half-way.**



The F-value (aperture value) and shutter speed are displayed at the right end of the LCD monitor.

The subject comes into focus and the exposure and white balance are fixed.

If the automatic focusing fails, the crosshairs in the center of the LCD monitor turn red and the auto-focus lamp in the upper right of the viewfinder blinks in green.

Auto Focus/Flash Lamp

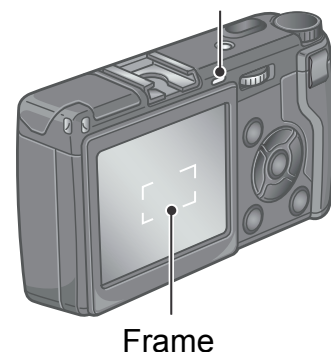

Frame

	Frame color	Auto Focus/Flash Lamp
Before focusing	White	Off
Focused	Green	On (green)
Focusing failure	Blink (red)	Blink (green)

The focal distance is measured at five points. Green frames appear to indicate focus positions.



## Reference

When specifying a focus position at macro shooting, use the AF target shift function. (P.94)

### 4. Gently press the shutter button all the way.

While the shot image is being written onto the card, the auto-focus/flash lamp blinks.

The still image you have taken freezes for a moment on the LCD Monitor and is recorded.





## Note

---

### Certain subjects are hard to bring into focus:

It may be impossible to bring the following subjects into focus.

- Subjects lacking contrast (the sky, a white wall, the hood of a car, etc.)
- Flat two-dimensional objects with only horizontal lines and no significant protrusions.
- Quickly moving objects.
- Things in poorly lit places.
- Areas with strong backlighting, or reflections.
- Things that flicker, such as fluorescent lights.

When you want to shoot subjects like this, first focus on an object the same distance as your subject and then shoot. (see P.40)

- Press gently to prevent camera shake when you press the shutter release button.
- During distance measurement for auto focusing, the white dot at the center of the cross on the LCD monitor blinks.
- The  mark indicates that blurring may occur. Hold the camera still and focus the camera again.
- When shooting in a dark place, the camera raises the focusing performance (auto focus precision) by preliminary flashing immediately before shooting. This preliminary flashing is skipped for shooting in no-flash mode.
- When the [LCD CONFIRM] is set to OFF in the setup screen, the still image shot will not be displayed on the LCD monitor.



## Reference

---

- For how to change the image confirmation time, see P.131.
- For how to change the focusing mode, see P.72.

# When the Subject is not Centered (Shooting with Focus-lock)

When your subject is not in the center of your composition, compose your photo after focusing. (Focus-lock)

Example: Taking a photograph of the castle in the background with the camera focused on a person in front.



- 1. Make sure the camera power is on and turn the mode dial to , P, A, or M.**
- 2. Put the subject of your photo right in the center of the LCD Monitor or the Viewfinder and press the shutter button half-way.**

The F-value (aperture value) and shutter speed are displayed at the right end of the LCD monitor and the subject comes into focus.
- 3. With the shutter half-pressed, move the camera and compose your shot.**



4. Gently press the shutter button all the way.



### Note



At macro shooting, the AF target shift function allows you to lock the focus without moving the camera. This function is useful when a tripod is used.





### Reference

- For details about macro shooting, see P.43.
- For details about the AF target shift function, see P.94.

# Using the Digital Zoom

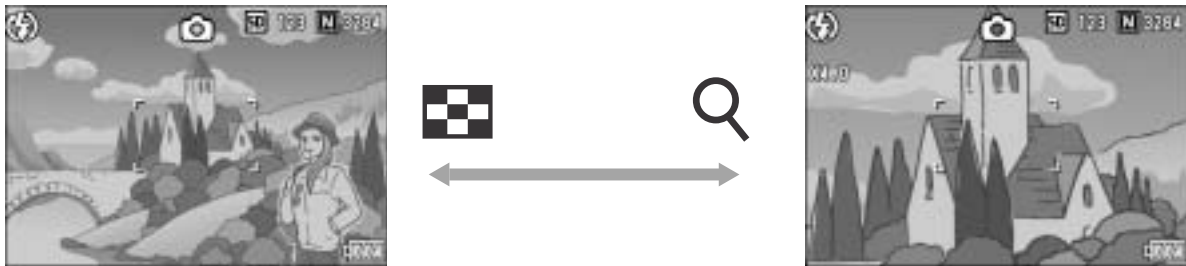
Set DIGITAL ZOOM on the SETUP menu (P.146) to ON to use the digital zoom function. When the digital zoom function is active, press the  button to enlarge the subject. Press the  button to reduce the subject. The digital zoom function can magnify the subject up to about 4 times the original size.



1. **With the camera ready to shoot, press the  or  button.**



The magnification is displayed on the LCD monitor.





2. **Compose your picture and half-press the shutter release button.**
3. **Press the shutter release button all the way.**



## Note

- When the digital zoom function is off, selecting [ZOOM BTN. SET.] on the SETUP menu allows you to assign the exposure compensation or white balancing to the   button.
- The digital zoom function cannot be used when [PIC QUALITY/SIZE] is set to RAW MODE.

## Reference

- For how to assign another function to the   button, see P.147.
- For how to turn on/off the digital zoom function, see P.146.



# Shooting Close-Ups (Macro-Mode)

Using the  (Macro) button allows you to take a tight close-up (Macro Photo). It is good for shooting small subjects because you can get up to 1.5 centimeter away.



1. **With the camera ready to shoot, press the  button.**

 is displayed momentarily in a large size at the center of the LCD monitor and then at the upper part.

2. **Compose your picture and half-press the shutter release button.**

3. **Press the shutter release button all the way.**

To get out of Macro Mode, press the  button again.



## Note







- The macro function allows you to shoot a subject at as close as approx. 1.5 cm from the front of the lens (shooting range: approx. 31 x 23 mm).
- During Macro Shooting, the Viewfinder cannot be used. Use the LCD Monitor.
- The AF target shift function enables you to lock the focus for macro shooting only by button operation without moving the camera. This function is useful for shooting on a tripod. (P.94)



# Using the Flash

Press the  (Flash) button to switch between flash modes. By default, your camera is set to Flash Off.

From the front edge of the lens, flashlight reaches about 0.2 to 3.0 m when ISO sensitivity is set to AUTO.

## Flash Modes

	Flash Off	The flash will not fire.
	Auto	When your subject is poorly lit or backlit, the flash fires automatically.
	Red-eye reduction	Reduces the red-eye phenomenon, in which people's eyes appear red when shooting images of people.
	Forced Flash	The flash fires, whatever the light conditions are, when you shoot.
	Slow Synchro	The flash fires with the shutter speed slowed. This is suitable when taking portrait pictures in a nightscape. It is recommended to use a tripod.
	External flash	Indicates that the external flash is attached.

- 1. Make sure the camera power is on and turn the mode dial to , P, A, M, or SCENE.**
- 2. Press the  (Flash) button to switch between flash modes.**

The Flash mode mark appears momentarily in a large size at the center of the LCD monitor and then is displayed at the upper left.

During flash charging, the flash lamp keeps blinking. Once the flash is charged, the lamp goes off and it is possible to shoot.

### Note

- When shooting in a dark place, the flash cover pops up automatically. After shooting, press down the flash cover in place.
- When other than the lithium-ion battery is used, the flash lamp icon is not displayed on the LCD monitor during flash charging.
- The settings are saved until you press the  (Flash) button to change them.
- When shooting movies or in Multi-Shot mode, the flash turns off.
- The flash fires twice to increase the AE/AF (Auto Exposure/Auto Focus) accuracy.
- The camera has a hot shoe, allowing you to attach an external flash (available in stores). (P.45)

## Using the Hot Shoe

The camera has a hot shoe, allowing you to attach an external flash (available in stores).

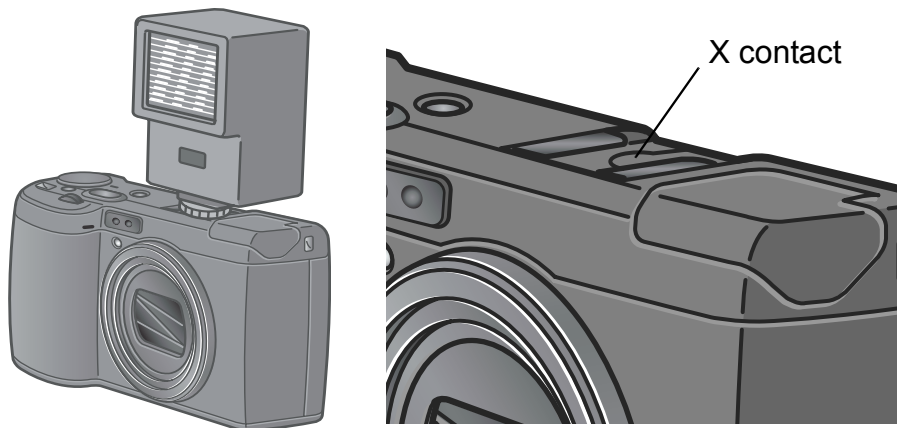

Certain models of external flashes are recommended for the camera. When using a recommended external flash, follow the operation procedure described on P.189.

When using an external flash other than the recommended one, follow the steps below.

- 1. Select FLASH OFF as the flash mode of the built-in flash. (P.44)**
- 2. With the camera and external flash powered off, attach the external flash to the hot shoe.**
- 3. Turn on the camera, turn the Mode Dial to A or M, and set the aperture value. (P.96, P.97)**
- 4. Set the ISO sensitivity to a value other than AUTO.**
- 5. Turn on the external flash, turn its mode to AUTO, and set the F-value and ISO sensitivity to the camera-set values.**

Be sure to turn off the external flash before detaching the external flash from the camera.



## Note

---

When a recommended external flash is attached, the built-in flash does not fire.





## Caution

---

- When using an external flash only or if the internal flash does not pop up normally when an external flash is connected, set the internal flash to [Flash Off].
- Irrespective of flash setting, a flash ON signal is output to the X contact of the hot shoe. To stop an external flash, use a switch on the flash.
- Exposure may not be appropriate even when the f-number and ISO sensitivity of the external flash are the same as those of the camera. If so, change the f-number and ISO sensitivity of the flash.
- As the flash ON signal, the camera outputs a positive pulse to the X pulse contact.
- A flash on the market rarely have an X contact of the opposite polarity. This kind of flash may not only not work but also cause a problem to the camera. For the terminal specifications, contact the manufacturer of the external flash.
- Use an external flash of a lighting angle covering the angle of view of the shooting lens.
- Use an external flash basically at a distance where the internal flash is not adequate (long distance). Shooting at a short distance may end in over-exposure.
- Do not use an external flash having a special signal pin. Using such a flash may cause inappropriate exposure or damage of the camera circuit.

# Shooting with Scenery-Matching

If you use the Scene Mode, you can record texts and sounds.

	Text	Use when shooting texts (e.g., memos written on a white-board in a conference).
	Sound	Use when recording sounds.

1. Turn the Mode Dial to **SCENE** .

2. Press the **▶** button.

The scene-selection screen is displayed.



3. Press the **▲▼** buttons to select **[TEXT MODE]** or **[SOUND MODE]**.

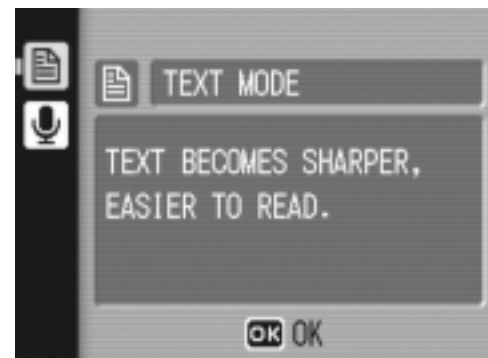

4. Press the **MENU/OK** button.

The Mode's symbol is displayed on the upper part of the LCD monitor.

5. Press the **shutter release** button.

Now you can shoot texts using Text mode.

For how to record sounds, see P.108.

If you press the **▶** button, the scene

selection screen appears and you can change the mode.



## Reference

- For how to change the image quality and size, see P.69.
- For how to change the text density in Text mode, see P.93.
- For the list of shooting setting menus displayed in the Scene mode, see P.190.

# Playing Back











## Checking the image you just took (Quick Review)

You can view the image you just took on the LCD monitor. If you are not pleased with the way the photo came out, you can erase it then and there.

1. While still in the Still Image Mode, press the  (Quick Review) button.

The last image you took is displayed on the LCD monitor.



In Quick Review	
 Button	Returns to Shooting Mode.
 Button	Enlarges the displayed still image. You can move around on the displayed image by pressing the     buttons.
 Button	Reduces the displayed still image enlarged by pressing the  button.
MENU/OK Button	Displays the still image at the maximum available ratio by pressing the  button. When displayed for the maximum size, it returns to a whole display.
 Button	Deletes the currently displayed file. When the  button is pressed, a warning message about deleting the file appears. Select [DELETE] and press the MENU/OK button.

### Note

- Once the power is turned off, the image you took cannot be displayed in the still image mode even if you press the  button.
- If you use Quick Review to view the image taken in Text mode (see P.47), the displayed image may have slightly lower quality than the recorded one.

# Viewing Your Images

In the Playback Mode you can check still images you have taken. You can also delete or zoom in on them.

## 1. Press the (Playback) button.

The camera switches to Playback mode and the last still image you took is displayed.

You can view your pictures in order by using the  button.

To switch the camera from playback mode to still image mode (or movie or voice memo mode), press the Playback button again.



## Caution

If you happen to delete a JPEG file corresponding to the DNG file shot in RAW mode, the thumbnail of the DNG file can only be viewed but not displayed in an enlarged view.

## Note

When an image is shot in RAW mode (RAW3264/RAW3:2), the corresponding JPEG image (F3264/F3:2) appears. In this case, the **RAW** mark standing for RAW is displayed.

### About power-on in playback mode

When the camera power is off, pressing the Playback button for more than one second turns on the camera. (The camera starts up in Playback Mode.)

When the camera is turned on with the Playback button, pressing the Playback button again switches Playback Mode to Shooting Mode.

### Where images are played back from

When no SD memory card is inserted, the camera plays back from the internal memory. When an SD memory card is inserted, it plays back from the SD memory card.

## Reference

- For how to playback movies, see P.107.
- For how to playback sounds, see P.109.
- For how to playback still images with voice memo, see P.85.

## Playing back in the three-frame view

---

A playback view can be divided into three frames. The three-frame view allows you to select a still image to enlarge or delete it.

1. Press the  (Playback) button.

The last image you took is displayed.



2. Press the  (Thumbnail Display) button.



The screen changes to the three-frame view. The large frame at the center displays the still image now selected.



To switch to single-picture display:

1. Press the  buttons to select a still image.
2. Press the  (Enlarge) button or the MENU/OK button.



# About Screen Switching at Playback

The playback screen changes as follows:



## Note

If one of the following operations is performed on the three-frame view, the display returns to the ordinary playback screen (single-picture display) and the operation is executed.

- Deletion (P.56)
- Movie playback (P.107)
- Sound playback (P.109)

## Reference

For how to erase unwanted Images, see P.56.

# Thumbnail Display

---

You can view your images in sets of 12.  
You can then select an image to erase or magnify.

**1. Press the  (Playback) button.**

The last image you took is displayed.

**2. Press the  (Thumbnail Display) button.**

The screen changes to three-frame view.

**3. Press the  (Thumbnail Display) button.**

The screen is divided into 12 frames and displays 12 still images at once.



Selected still image

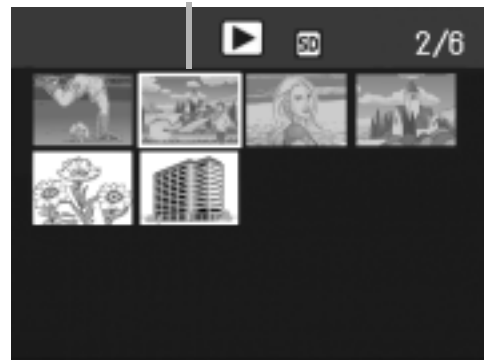

## To display just one photo

**1. Use the     buttons to select an image.**

**2. Press the  (Enlarged Display) button twice.**



## Reference

---

- For how to erase the selected image, see P.57.
- For how to switch to the three-frame view, see P.50.

# Magnifying Images

You can enlarge a still image displayed on the LCD Monitor.

3264 X 2448, 3264 X 2176, 2592 X 1944, 2048 X 1536	8 times
1280 X 960	6.7 times
640 X 480	3.4 times

**1. Press the  (Playback) button.**





The last image you took is displayed.

**2. Press the  buttons to display the still image you want to enlarge.**

**3. Press the  (Enlarged View) button.**

The still image is enlarged.



In Enlarged View	
 Button	Enlarges the displayed still image. You can move around on the displayed image by pressing the  buttons.
 Button	Reduces the displayed still image enlarged by pressing the  button.
MENU/OK Button	Displays the still image at the maximum magnification ratio. Displays the still image at the maximum available ratio or returns it to its original size.

# Viewing on a Television

You can view still images you have taken on a TV screen. The camera displays everything on the TV screen just as it would on the LCD Monitor.

To use your television for viewing, connect your camera to the television with the AV cable that came with your camera.

To view still images on a television, follow the steps below.

**1. Securely connect the AV cable to the Video In terminal on the television.**

Connect the white plug of the AV cable to the audio input terminal (white) of the TV unit and the yellow plug to the video input terminal (yellow).

Video input terminal (yellow)

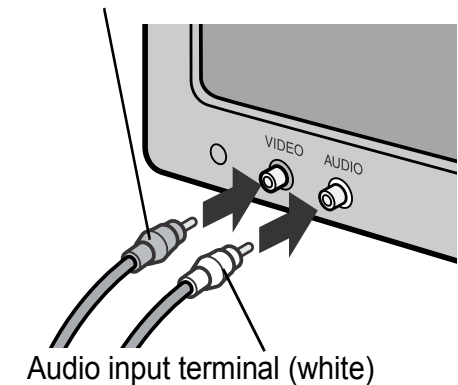

**2. Make sure the camera power is off.**

**3. Securely connect the AV cable to the Video Out terminal.**

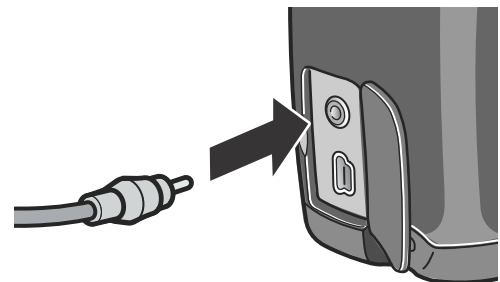

**4. Set the television to "Video" mode. (Set the input to "Video".)**

For details, see the documentation that came with the television.

5. Press the Power button or keep pressing the Playback button for more than one second to turn the camera on.



### Caution

Connecting the AV cable to the camera turns off the LCD monitor display and the speaker output.

### Note

- If you connect the AV cable to your video recorder's In terminal, you can record what you have shot onto video.
- Your camera is set to NTSC playback format (used in Japan and other countries) for use with television equipment, etc. If the equipment you want to connect to uses PAL format (used in Europe and else-where), then switch your camera to PAL format in the Setup Menu before connecting.

### Reference

For how to change the video out mode, see P.136.

# Erasing

## Erasing Unwanted Files (Still Images/Movies/Sounds)



You can erase unwanted or failed files from the SD memory card or internal memory.

You can erase them in the following three ways:

- One file at a time
- Deleting all frames at once
- Select multiple frames and erase together

1. Press the  (Playback) button.
2. To erase images one at a time, press the  buttons to display the file you want to erase.
3. Press the  (Delete) button.



4. Press the  buttons to select [DELETE ONE] or [DELETE ALL].  
If you selected [DELETE ONE], you can also change the image for deletion with the  buttons.



5. Press the MENU/OK button.

### If you selected [DELETE ONE]:

The display indicates deletion is in progress; once finished, it returns to the screen in step 4.

### If you selected [DELETE ALL]:

You will be prompted to confirm that you want to erase; if so, press the  button to select [Yes], and then press the MENU/OK button.

### Note

In the three-frame view (see P.50), you can display a still image at the center and press the  (Delete) button to delete it.

# Erasing Multiple Frames at One Time

1. Press the  (Playback) button.



2. Press the  (Thumbnail) button twice.

The screen is divided into 12 frames and displays 12 still images at once.



3. Press the     buttons to select the image you want to erase and press the  (Delete) button.

The trash symbol is displayed in the upper left corner of the image.

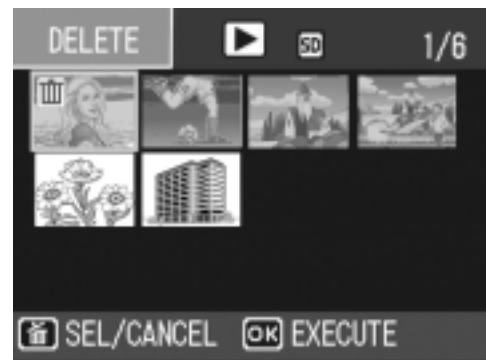

4. Repeat Step 3. to select all the still images you wish to erase.

If you selected an image by mistake, you can deselect it by selecting the image and pressing the  (Delete) button again.

5. Press the MENU/OK button.

6. Press the  button to select [YES] and then press the MENU/OK button.

The display indicates deletion is in progress; once finished, the Thumbnail Display screen returns.





# Chapter 2

## A Variety of Shooting Techniques/Playback

Direct Printing .....	60
A Variety of Shooting Techniques .....	65
Shooting with Multi-Shot .....	101
Shooting/Playing Back Movies.....	105
Recording/Playing Back Sound .....	108
Other Functions Available in Playback Mode.....	110

# Direct Printing

## Direct Print Function

---

The Direct Print standard enables direct printing from a camera to a printer, by connecting them via a USB cable. Photos can be printed quickly and easily from your digital camera without using a computer.



### Caution

---

- You cannot print movies (.AVI) with this function. For still images with sounds (.JPG and .WAV), only the still images (.JPG) are printed.
- Some printer does not support images taken in Text mode (TIFF). Even when TIFF images are printed, their printed contents cannot be guaranteed.
- When an image is shot in RAW mode, the corresponding JPEG file is printed. The .DNG file cannot be printed.



### Note

---

- This camera uses PictBridge, an industry standard for Direct Printing.
- Your printer must comply with the PictBridge to use the Direct Print function. For support information, see the documentation that came with the printer.
- For direct printing on a printer supporting both Direct Print and PictBridge, select [Original] for [USB Connection].

## Connecting the Camera to a Printer

---

Connect your camera to a printer using the USB cable provided.

- 1. Make sure the camera power is off.**
- 2. Connect your camera to a printer using the USB cable provided.**

Turn on the printer, if it is off.



### Note

---

To disconnect the camera from the printer, check that the power is off on both units before disconnecting the USB cable between them.

# Printing Still Images

You can send still images from the camera to a PictBridge compatible printer to print them.

Still images are sent from the internal memory when no SD memory card is loaded or from an SD memory card when one is loaded.

## Caution

Do not disconnect the USB cable during printing.

## Note

If a printer error message appears during transmission, check the condition of the printer, and take the appropriate action.

## Printing One or All Still Images

### 1. Check that the printer is ready for printing.

The "Connecting" screen appears.

### 2. Press the ADJ. dial.

The Direct Print playback mode screen appears.

### 3. Press the ◀▶ buttons to select an image for printing.

### 4. Press the ADJ. dial.

### 5. Press the ▲▼ button to select [1 FILE] or [ALL FILES].

### 6. Press the MENU/OK button.

The Direct Print menu appears.

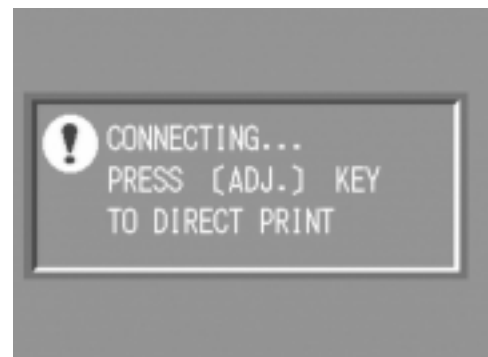

7. Press the ▲▼ buttons to select an item, and then press the ► button to display the detailed options screen.

While "CONNECTING..." is displayed, connection to the printer is still incomplete. When printer connection is completed, "CONNECTING..." disappears and "DIRECT PRINT" appears. Proceed to the next step after the connection is complete.

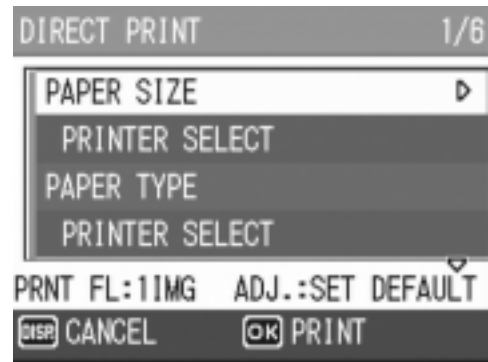

The following items can be selected. Each item appears only when supported by the printer.

Item Name	Function
PAPER SIZE	Sets the paper size.
PAPER TYPE	Sets the paper type.
LAYOUT	Sets the number of images printed on a sheet of paper. The number of images that can be laid out on a sheet of paper varies depending on the type of the connected printer.
DATE PRINT	Selects whether to print the date (shooting date). The date format can be set using the date/time option in the <b>SETUP</b> Mode.
FILE NAME PRINT	Selects whether to print the file name.
OPTIMIZE IMAGE	Selects whether to optimize the image data (still image) prior to printing on the printer.
FIXED-SIZE PRINT	Setting the print image size.
PRINT QUALITY	Setting the print quality.
FORMS PRINT	Printing forms.

8. Press the ▲▼ buttons to select the detailed item, and then press the MENU/OK button.

The display returns to the Direct Print menu.

9. Repeat steps 7 and 8 to change the settings as required.

## Note

To specify the set value as the default selected at the next connection, click the ADJ. dial on the screen of Step 7. Upon appearance of the screen at right, select [Set] and press the MENU/OK button. Select [Cancel] to return to the default setting.



2

### 10. Press the MENU/OK button.

The selected still images are sent to the printer and the "Connecting" screen appears.

Press the DISP. button to cancel the operation.

At the end of transmission, the display returns to the Direct Print playback mode screen and printing starts.

## Printing Several Still Images

### 1. Check that the printer is ready for printing.

The "Connecting" screen appears.

### 2. Press the ADJ. dial.

The Direct Print playback mode screen appears.

### 3. Press the (Thumbnail) button twice.

The screen is divided into 12 frames and displays 12 still images at once.

### 4. Press the buttons to select an image for printing.

### 5. Press the MENU/OK button.

### 6. Press the buttons to set the number of copies to print.

Press the  button to increase the number, or the  button to decrease it.

### 7. Press the buttons to select an image for printing.

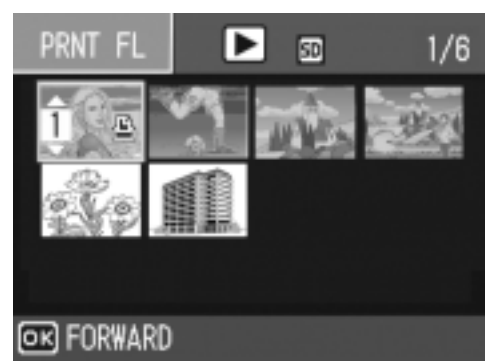
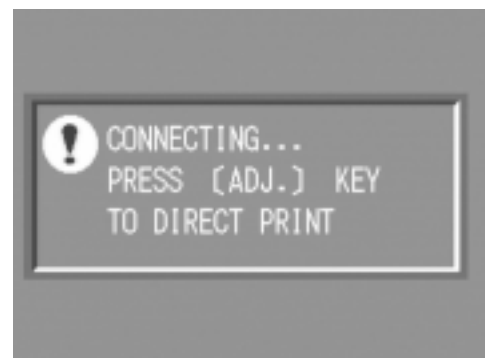

8. Press the ▲▼ buttons to set the number of copies to print.
9. Repeat steps 7 and 8 to select all the still images to be printed and the number of copies for each.

**10. Press the MENU/OK button.**

The Direct Print menu appears.

**11. Press the ▲▼ buttons to select an item, and then press the ► button to display the detailed options screen.**

While "CONNECTING..." is displayed, connection to the printer is still incomplete. When printer connection is completed, "CONNECTING..." disappears and "DIRECT PRINT" appears. Proceed to the next step after the connection is complete. For settings available, see P.62.

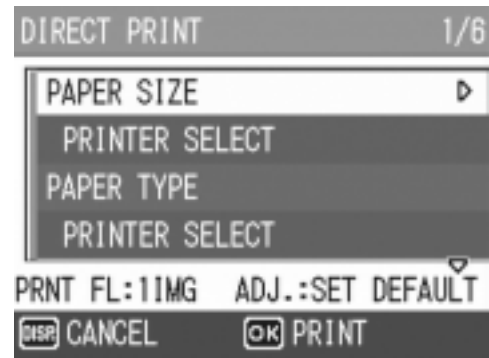

**12. Press the ▲▼ buttons to select the detailed item, and then press the MENU/OK button.**

The display returns to the Direct Print menu.

**13. Repeat steps 11 and 12 to change the settings as required.**

**14. Press the MENU/OK button.**

The selected still images are sent to the printer and the "Connecting" screen appears.

Press the MENU/OK button to cancel the operation.

When all the selected still images have been sent from the camera to the printer, the camera display returns to the Direct Print playback mode screen.



**Note**

- Only images with a printer mark (  ) are printed. When you cancel printing and then try to print again, make sure that the printer mark is on the images you want to print.
- The same still image can also be printed several times on a single sheet.
- The items available vary depending on the functions of the printer.
- To print images using the printer's default settings, select Printer Setting on the detailed options screen.

# A Variety of Shooting Techniques

## Using the ADJ. (Adjust) Mode

When you enter the ADJ. mode, you can display various setting screens with fewer dial operations and set functions with fewer button operations as compared with the Shooting menu. The ADJ. mode allows you to register two functions other than exposure correction and white balancing functions.

### Operation Flow in ADJ. Mode

#### 1. Press the ADJ. dial.

The camera enters the ADJ. mode, and the functions that can be set in this mode are displayed.



#### 2. Turn the ADJ. dial until the function you want to set is displayed.



#### 3. Use the ▲▼ buttons or up-down dial to change the setting.

#### 4. If you have another function to set, repeat steps 2 and 3.



#### 5. Press the MENU/OK button.

The ordinary shooting screen reappears.





## Note

To assign functions to [SETTING 1] and [SETTING 2], select [ADJ. BTN. SET. 1] and [ADJ. BTN. SET. 2] on the SETUP menu. (P.127)

## Settings that can be made with the ADJ. dial

Settings that can be made differ between the Scene mode and Movie mode.

Still Image Mode	Exposure, White Balance, ISO Setting, Pic Quality/Size, Focus, Image Setting, Photometry, Auto Bracket, Multi-Shot, Image with sound
Movie Mode	White Balance
Scene Mode (Text Mode)	Density
Scene Mode (other than Text Mode)	None



## Reference

- For how to assign functions to the ADJ. dial, see P.127.
- Exposure Comp, see P.87.
- White Balance, see P.88.
- ISO Setting, see P.91.
- Pic Quality/Size, see P.69.
- Focus, see P.72.
- Photometry, see P.77.
- Auto Bracket, see P.80.
- Multi-shot, see P.101.
- Image With Sound, see P.85.
- Density, see P.93.



# Shooting Setting Menu

The Shooting Setting menu enables you to shoot pictures by setting the items listed in the table below.

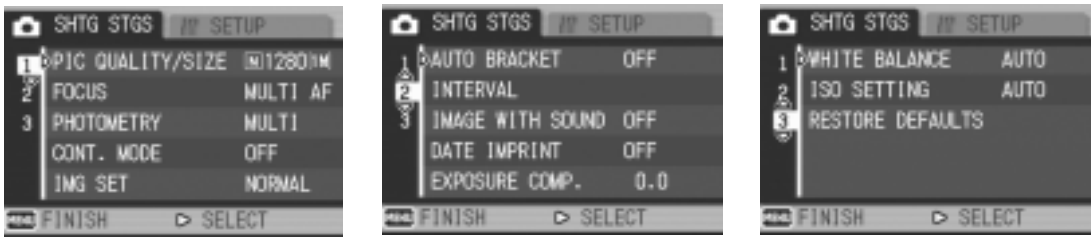

\*Among the choices listed in the table below, default values at purchase are enclosed in [ ].

Setting	Option	Refer to
PIC QUALITY/SIZE	RAW(8M), RAW3:2(8M), F3264(8M), F3:2(8M), [N3264(8M)], N2592(5M), N2048(3M), N1280(1M), N640(VGA)	P.69
FOCUS	[MULTI AF], SPOT AF, MF, SNAP, ∞	P.74
PHOTOMETRY	[MULTI], CENTER, SPOT	P.77
CONT. MODE	[OFF], CONT, SCONT, MCONT	P.101
IMG SET	HARD, [NORMAL], SOFT, B&W, SETTING1, SETTING2	P.78
AUTO BRACKET	[OFF], ON, WB-BKT	P.80
INTERVAL	[0 s], 5 seconds to 3 hours	P.83
IMAGE WITH SOUND	[OFF], ON	P.85
DATE IMPRINT	[OFF], DATE, TIME	P.86
EXPOSURE COMP.	-2.0 to +2.0	P.87
WHITE BALANCE	[AUTO],  (Daylight),  (Overcast),  (Tungsten light),  (Fluorescent light), [M] (Manual Setting), [LT] (Detail)	P.88
ISO SETTING	[AUTO], ISO64, ISO100, ISO200, ISO400, ISO800, ISO1600	P.91
RESTORE DEFAULTS	_____	P.92

## Reference

For the list of Shooting Setting menu items in Movie and Scene Modes, see P.190.

# Using the Shooting Setting Menu

1. **With the camera ready to shoot, press the MENU/OK button.**

The Shooting Setting menu appears.

2. **Press the ▲▼ buttons to select the desired item.**

The setting items are provided on 3 screens.

When the ▼ button is pressed at the bottom item, the next screen appears.

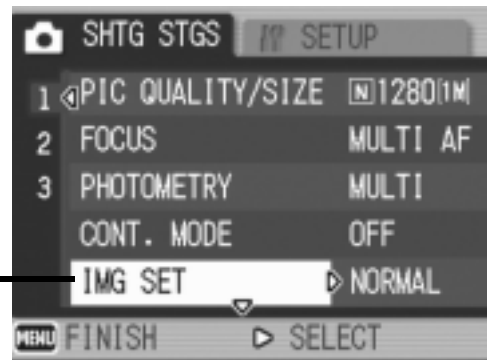

## To select a screen by screen number:

1. Press the ◀ button to select a screen number on the left of the screen.
2. With the screen number selectable, press the ▲▼ buttons to switch between screens.
3. After selecting the screen, press the ▶ button to return to the setting item selection step.

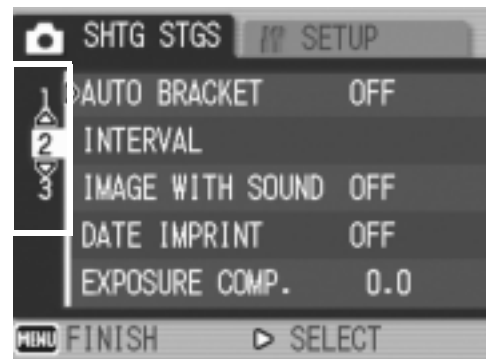

3. **After selecting a setting item, press the ▶ button.**

Choices for the setting item are displayed.

4. **Press the ▲▼ buttons to select a choice.**

5. **Press the MENU/OK or ◀ button.**



6. **If you pressed the ◀ button in step 5, press also the MENU/OK button.**

The Shooting Setting menu disappears and the camera becomes ready for shooting.

# Choosing Picture Quality Mode/Image Size (PIC QUALITY/SIZE)

The size of a stored still image and movie file depends on picture quality and size settings.

There are three types of picture quality modes: N (Normal), F (Fine), and R (RAW).

Types of Modes You Can Select		
Symbol	Mode	Description
	Normal Mode	The compression ratio is high, resulting in a small file. Normally, shooting is done in this mode.
	Fine Mode	The compression ratio is low, resulting in a large file, but the picture quality is better than in Normal Mode.
	RAW Mode	Raw data of shot images is saved as RAW files (.DNG files). JPEG files (Fine mode) converted from RAW files are also recorded. Generally, the shot images are compressed in the camera to be saved as JPEG files. The image quality of JPEG files degrades due to compression although their file size is small. RAW files are saved as raw data without being processed in the camera. You can edit RAW files as desired using image processing software without degrading the initial image quality of the shot images.

The aspect ratio of 3:2 can be used in RAW and Fine modes. (Default aspect ratio = 4:3)

## Note

The DNG files created in the RAW mode store the raw data from the camera's sensor. The data close to the original can be edited as desired using the application software compliant with the DNG file format.

The DNG file format, one of RAW file formats, is the standard file format advocated by Adobe Systems Inc.

## Combining Picture Quality Mode and Image Size.

Mode	Size	On screen display	Uses
RAW	3264 X 2448	RAW (8M)	Images can be created with less quality degradation. This mode is suitable for high-level image correction and editing on the computer.
	3264 X 2176	RAW3:2 (8M)	
F (Fine)	3264 X 2448	F3264 (8M)	Suitable for downloading images to your computer and correcting the images or printing them in large sizes.
	3264 X 2176	F3:2 (8M)	
N (Normal)	3264 X 2448	N3264 (8M)	Suitable for printing images in large sizes.
	2592 X 1944	N2592 (5M)	
	2048 X 1536	N2048 (3M)	Suitable for shooting many pictures.
	1280 X 960	N1280 (1M)	
	640 X 480	N640 (VGA)	

In Movie Mode, 320 X 240 or 160 X 120 can be selected.



### Note

- In RAW mode, you cannot use the functions such as Multi-Shot, Auto Bracket, White Balance Bracket, Digital Zoom, and Image with Sound.
- DNG files shot in the RAW mode must be processed with the image processing software installed on the computer. They can be processed with the provided software, Adobe Photoshop Elements (Trial Version) (P.177).
- DATE IMPRINT cannot be used with RAW mode.
- In RAW mode, the sharpness, color depth, and other image settings made using the Shooting menu are reflected only in JPEG files.
- In RAW mode, the ISO sensitivity is fixed to 800 even if it is set to 1600.



### Reference

For internal memory/SD memory card recording capacities, see P.192.

1. **Make sure the camera power is on and turn the mode dial to , P, A or M.**
2. **Press the MENU/OK button.**  
The Shooting Setting menu appears.
3. **Press the ▼ button to select [PIC QUALITY/SIZE] and press the ► button.**
4. **Press the ▲▼ buttons to select a picture quality/size.**
5. **Press the MENU/OK or ◀ button.**  
Picture Quality/Image Size settings are completed.

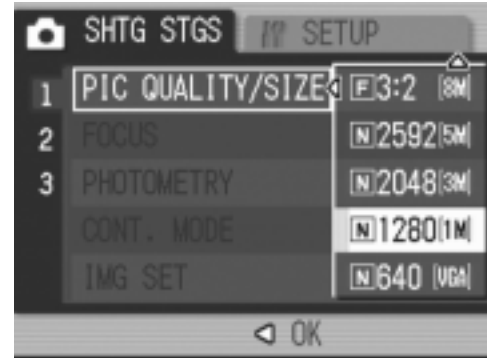

Still Image Mode

6. **If you pressed the ◀ button in step 5, press also the MENU/OK button.**

The shooting setting menu disappears and the LCD monitor displays the set values.

This setting will be used for shooting until you change it.

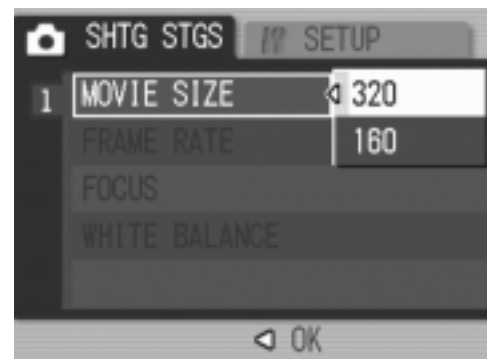

Movie Mode

## Changing the Focusing Mode (FOCUS: MULTI AF/SPOT AF)



---

If you shoot the subject in the default focusing mode, the camera focuses automatically (AF).









The camera automatically measures the distances to 15 AF areas and focuses on the nearest AF area (MULTI AF), preventing the central area of the subject from becoming out of focus and allowing you to shoot with a minimum number of out-of-focus pictures.

You can select only one AF area at the center of the LCD monitor to allow the camera to focus on this area (SPOT AF).

Five different focusing modes are supported.

Selective focusing modes		
Mark	Mode	Description
None	MULTI AF	Automatically measures the distances to multiple areas to adjust the focus.
None	SPOT AF	Measures the distance to the central area of the subject to adjust the focus automatically.
	MANUAL FOCUS (MF)	Allows you to adjust the focus manually.
	SNAP	Fixes the shooting distance to short distance (about 2.5 m).
	Infinity ( ∞ )	Fixes the shooting distance to infinity.

## Changing the Auto Focusing Mode (MULTI AF/SPOT AF)

1. **Make sure the camera power is on and turn the mode dial to , P, A, M or .**
2. **Press the MENU/OK button.**  
The Shooting Setting menu appears.
3. **Press the  button to select [FOCUS] and press the  button.**
4. **Press the   buttons to select [MULTI AF] or [SPOT AF].**
5. **Press the MENU/OK button or  button.**
6. **If you pressed the  button in step 5, press the MENU/OK button.**  
Now you are finished with the focus setting.  
The Shooting Setting menu closes.

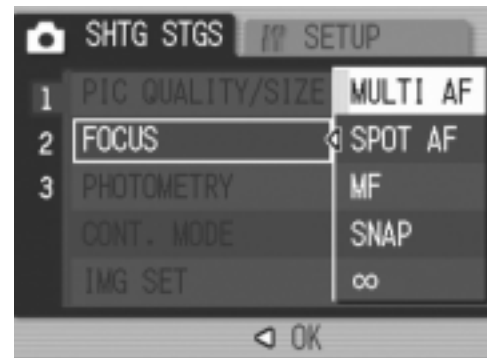

### Reference

- For details about fixing the shooting distance to Snapshot or Infinity ( ∞ .), see P.76.
- For details about manual focusing (shooting with manual focusing), see P.74.

# Manual Focus Shooting (FOCUS: MF)

If the camera fails in focusing automatically, you can focus manually (Manual Focus: MF).

Manual focusing allows shooting at a fixed distance. When using a fixed shooting distance, it can be set to either Snapshot or Infinity ( $\infty$ ).



## Note

- Manual focus cannot be used in Scene Mode.
- Manual focusing can focus the camera also on an object that requires macro shooting.

## Setting Manual Focusing

1. **Make sure the camera power is on and turn the mode dial to , P, A, M or .**

2. **Press the MENU/OK button.**

The Shooting Setting menu appears.

3. **Press the  button to select [FOCUS] and press the  button.**

4. **Press the   buttons to select [MF].**

5. **Press the MENU/OK or  button.**

Focus settings are complete.

6. **If you pressed the  button in step 5, press also the MENU/OK button.**

Now you have finished focus setting. The Menu closes and "MF" is displayed on the screen.

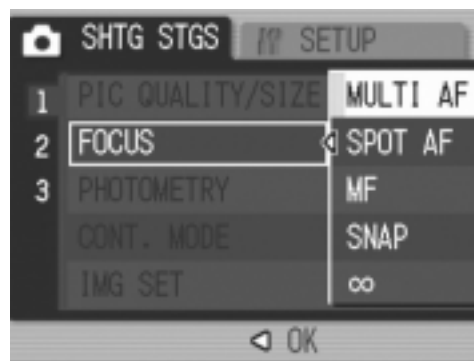



## Shooting with Manual Focusing

### 1. Press the ▼ button as required.

Pressing the ▼ button enlarges the display for easy focusing.

### 2. Press the ◀ button to display the focus bar.

### 3. Press the 🔍 and 📐 buttons for focusing.

Pressing the 🔍 button moves the focus away from you.

Pressing the 📐 button brings the focus closer to you.

Until the setting is changed the next time, pictures are shot by manual focusing.

### 4. Press the shutter button for shooting.



## Reference



- For details about setting to Auto Focus (Multi AF/Spot AF), see P.72.
- For details about fixing the shooting distance to Snapshot or Infinity, ( $\infty$ ), see P.76.
- For details about changing the shutter speed, see P.97, P.99.

# Shooting at a Fixed Distance (FOCUS: SNAP/∞)

---

The shooting distance can be set to short distance or infinity. Infinity is useful to shoot a distant view.

To shoot with the shooting distance fixed, follow the steps below.

- 1. Make sure the camera power is on and turn the mode dial to , P, A, M or .**
- 2. Press the MENU/OK button.**  
The Shooting Setting menu appears.
- 3. Press the ▼ button to select [FOCUS] and press the ► button.**

- 4. Press the ▲▼ buttons to select [SNAP] or [∞] (Infinity).**

Selecting [SNAP] will fix the shooting distance to 2.5 meters.

Selecting [∞] will fix the shooting distance to infinity.



- 5. Press the MENU/OK or ◀ button.**
- 6. If you pressed the ◀ button in step 5, press also the MENU/OK button.**

Now you have finished focus setting.



The Shooting Setting menu closes and the setting value appears on the screen.

This setting will be used for shooting until you change it.

# Changing the Light Metering (PHOTOMETRY)

You can change the metering method (the range to use for metering) to determine the exposure value.

There are three Light Metering Methods available: MULTI, CENTER, and SPOT.

Types of Modes You Can Select		
Symbol	Mode	Description
(No Symbol)	MULTI	The entire shooting range is divided into 256 partitions, and subjected to photometry for overall decision.
	CENTER	The light metering is determined by a measurement of the whole, with the central part emphasized. Use this when the brightness of the center and surroundings are different.
	SPOT	Light metering is determined by measuring only the central part. Use this setting when you want to use the brightness of the center. It is useful if there is marked difference in contrast or backlighting.

- 1. Make sure the camera power is on and turn the mode dial to , P, A or M.**
- 2. Press the MENU/OK button.**  
The Shooting Setting menu appears.
- 3. Press the ▼ button to select [PHOTOMETRY] and press the ► button.**
- 4. Press the ▲▼ buttons to select the desired setting.**
- 5. Press the MENU/OK or ◀ button.**
- 6. If you pressed the ◀ button in step 5, press also the MENU/OK button.**

The shooting setting menu disappears and the LCD monitor displays the set values.

This setting will be used for shooting until you change it.

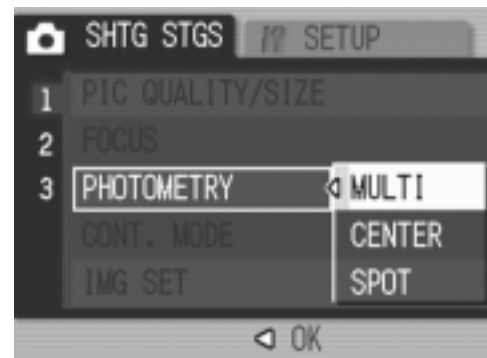

# Setting the Image Quality (IMG SET)

You can select an image quality type from Normal, Hard Tone, Soft Tone, Black and White, Setting 1, and Setting 2.

Type	Description
Normal	Normal image quality.
Hard	The contrast, sharpness, and color density are set at levels slightly higher than usual, making the image look hard.
Soft	The contrast, sharpness, and color density are set at levels slightly lower than usual, making the image look soft.
B&W	Monochrome image.
Setting 1	You can select a contrast level, sharpness level, and color depth level from among five levels respectively to set the image quality of the original as required.
Setting 2	

## Selecting the Image Quality

**1. Make sure the camera power is on and turn the mode dial to , P, A or M.**

**2. Press the MENU/OK button.**

The Shooting Setting menu appears.

**3. Press the ▼ button to select [IMG SET] and press the ► button.**

**4. Press the ▲▼ buttons to select the Image setting.**

If you selected [SETTING 1] or [SETTING 2], set the desired values. If they have already been set for [SETTING 1] or [SETTING 2], just select [SETTING 1] or [SETTING 2] to set the image quality.

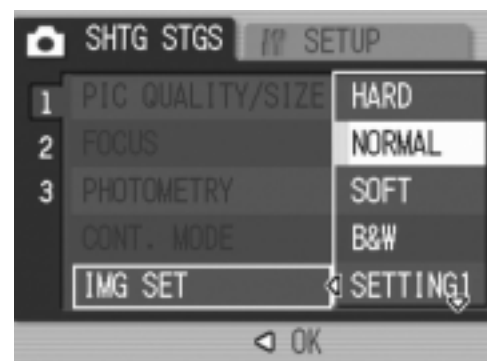

**5. Press the MENU/OK or ◀ button.**

**6. If you pressed the ◀ button in step 5, press also the MENU/OK button.**

Now you have finished focus setting.

The shooting setting menu disappears and the LCD monitor displays the set values.

This setting will be used for shooting until you change it.



## Setting the Values for [SETTING 1] or [SETTING 2]

1. **Make sure the camera power is on and turn the mode dial to , P, A or M.**

2. **Press the MENU/OK button.**

The Shooting Setting menu appears.

3. **Press the  button to select [IMG SET] and press the  button.**



4. **Press the   buttons to select [SETTING 1] or [SETTING 2].**

5. **Press the  button.**

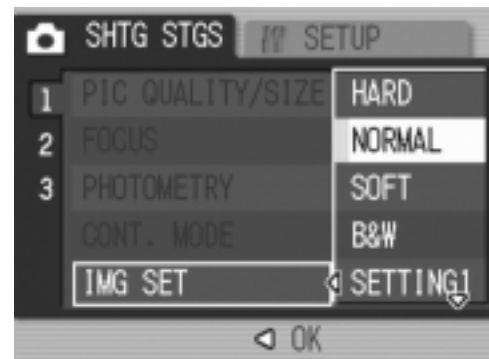
The customizing menu appears.



6. **Using the   buttons, set the contrast, sharpness, and color depth levels.**

To move between [CONTRAST], [SHARPNESS], and [COLOR DEPTH], use the   buttons.



7. **Press the MENU/OK button.**

8. **Press the MENU/OK or  button.**

9. **If you pressed the  button in step 8, press also the MENU/OK button.**

Now you have completed settings for [SETTING 1] or [SETTING 2].

If you shoot immediately, the values set for [SETTING 1] or [SETTING 2] are applied.

# Shooting Consecutively with Different Exposures (AUTO BRACKET)

The Auto Bracketing function automatically shoots three consecutive shots, with the specified exposure value as standard, at three exposure levels, at -0.5EV,  $\pm 0$ , and +0.5EV.

## Note

- This function is not available when shooting with sound.
- This function cannot be used when [PIC QUALITY/SIZE] is set to RAW.

**1. Make sure the camera power is on and turn the mode dial to , P, A or M.**

**2. Press the MENU/OK button.**

The Shooting Setting menu appears.

**3. Press the  button to select [AUTO BRACKET] and press the  button.**

**4. Press the   buttons to select [ON].**

**5. Press the MENU/OK or  button.**

The shooting setting menu disappears and the LCD monitor displays [AB].

**6. If you pressed the  button in step 5, press also the MENU/OK button.**

**7. Press the shutter release button.**

Three consecutive shots are taken, with the specified Exposure Compensation value as the standard, at -0.5EV,  $\pm 0$ , and +0.5EV.

After shooting, three still images are displayed on the LCD Monitor. They are, from the left, at -0.5EV (darker), standard compensation, and +0.5EV (brighter).

This setting will be used for shooting until you change it or you turn the power off.

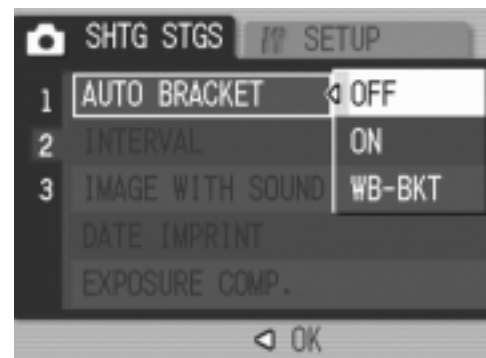

## Reference

- For how to change the Exposure Compensation, see P.87.
- For how to change the White Balance, see P.88.

# Shooting Consecutively with Different White Balance (WHITE BALANCE BRACKET)

Three images are automatically recorded - a reddish image, a bluish image, and an image of the current white balance.

This is useful if the appropriate white balance cannot be judged.

- 1. Make sure the camera power is on and turn the mode dial to , P, A or M.**
- 2. Press the MENU/OK button.**  
The Shooting Setting menu appears.
- 3. Press the ▼ button to select [AUTO BRACKET] and press the ► button.**
- 4. Press the ▲▼ buttons to select [WB-BKT].**
- 5. Press the MENU/OK or ◀ button.**
- 6. If you pressed the ◀ button in step 5, press also the MENU/OK button.**

Now you have finished white balance bracket setting.

The Shooting Setting menu disappears and the screen displays [WB-BKT].

- 7. Press the shutter release button.**

Three images (reddish, bluish, and equal to the current white balance) are automatically recorded.

This setting will be used for shooting until you change it or you turn the power off.

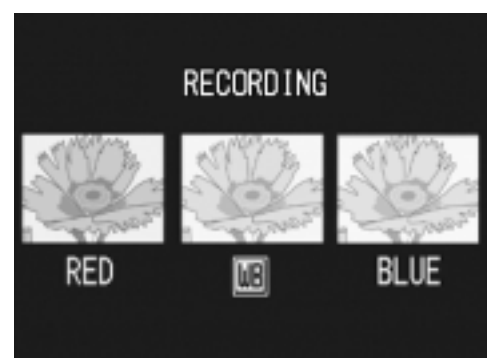
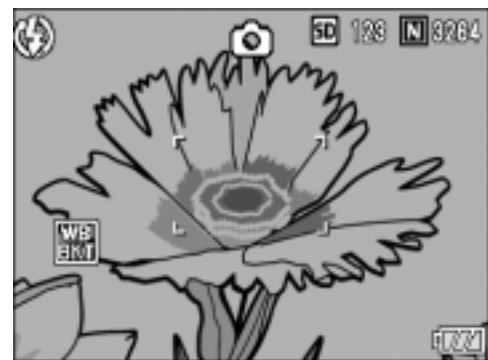
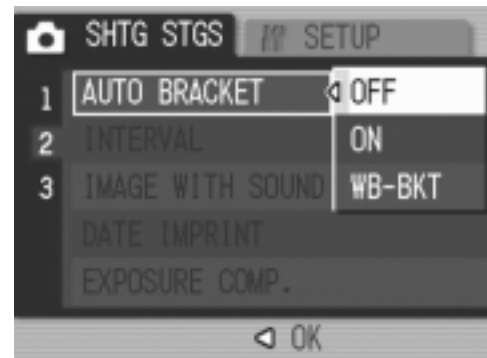



## Note

---

- This function is not available for Multi-Shot shooting (P.101) and Auto Bracket shooting (P.80).
- The flash cannot be used.
- If [B&W] is set for [IMG SET], the white balance bracket can be set but does not become valid.
- This function cannot be used when [IMAGE QUALITY/SIZE] is set to RAW.



## Reference

---



For how to change the White Balance, see P.88.









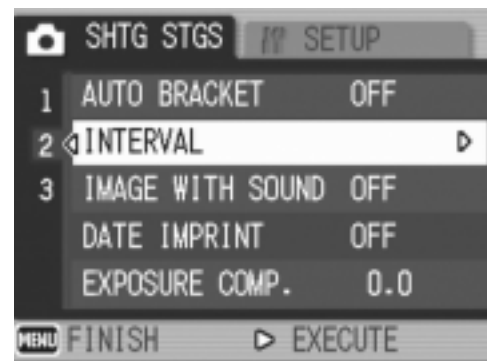

# Shooting Pictures Automatically at Set Intervals (INTERVAL)

You can set the camera to automatically take pictures at fixed intervals.

You can set the shooting interval at any length from 5 seconds to 3 hours, in increments of 5 seconds.

1. **Make sure the camera power is on and turn the mode dial to , P, A or M.**
2. **Press the MENU/OK button.**  
The Shooting Setting menu appears.
3. **Press the  button to select [INTERVAL] and press the  button.**



4. **Press the  buttons to specify the length of time.**
5. **Press the  button to move to the minutes setting, then use the  buttons to set the minutes.**
6. **Press the  button to move to the seconds setting, then use the  buttons to set the seconds.**
7. **Press the MENU/OK button.**

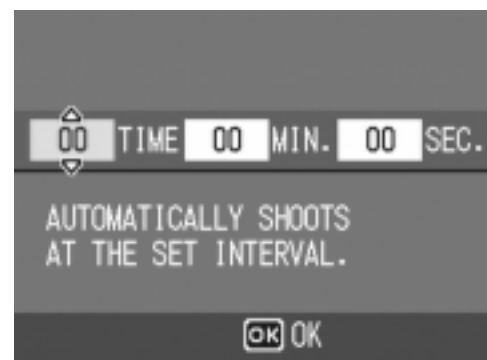

Interval shooting is set and the LCD monitor displays "Interval".



## 8. Press the shutter release button.

A picture is taken every time the fixed interval elapses.

## 9. To stop shooting, press the MENU/OK button.

Interval Shooting settings are cleared when the power is turned off.

### Caution

---

If the time until the next shooting is set longer on the shooting menu than the time for interval shooting, the shooting interval becomes longer than that for interval shooting.







### Note

---

- In step 5, press and hold either the ▲ or ▼ button to quickly raise or lower the setting value for minute.
- If you use batteries for power, you may exhaust the batteries. Using the AC Adapter (sold separately) is recommended.
- Even during Interval Shooting, if you press the shutter button, the camera will shoot as usual. However, Interval Shooting Mode is unaffected. After shooting, once the time specified in Interval Shooting elapses, the next shot is taken.
- When Interval Shooting is on, even when Multi-Shot is set to [CONT] or [MCONT], consecutive shooting is automatically switched off.





# Shooting a Still Image with Sound (IMAGE WITH SOUND)

You can shoot a still image with a voice memo. Voice recording can continue for up to eight seconds.

1. **Make sure the camera power is on and turn the mode dial to , P, A or M.**
2. **Press the MENU/OK button.**  
The Shooting Setting menu appears.
3. **Press the  button to select [IMAGE WITH SOUND] and press the  button.**
4. **Press the  buttons to select [ON].**
5. **Press the MENU/OK or  button.**
6. **If you pressed the  button in step 5, press also the MENU/OK button.**  
The Shooting Setting menu disappears.
7. **Press the shutter release button for shooting.**  
After shooting, the voice mark appears on the screen to indicate the recording status.
8. **Press the shutter release button to stop recording.**



## Note

- This function cannot be used when [IMAGE QUALITY/SIZE] is set to RAW.
- When playing back a still image with sound, display the image in the same way as an ordinary image without voice. Pressing the shutter release button plays back the sound. Press the  buttons to display the volume adjustment bar, where you can adjust the volume with the  buttons.

## Reference

For how to display still images, see P.49.

# Inserting the Date into a Still Image (DATE IMPRINT)

---

You can insert the date (YY/MM/DD) or the date and time (YY/MM/DD hh:mm) at the lower right of a still image.

1. **Make sure the camera power is on and turn the mode dial to , P, A or M.**
2. **Press the MENU/OK button.**  
The Shooting Setting menu appears.
3. **Press the ▼ button to select [DATE IMPRINT] and press the ► button.**
4. **Press the ▲▼ buttons to select the desired setting.**
5. **Press the MENU/OK or ◀ button.**

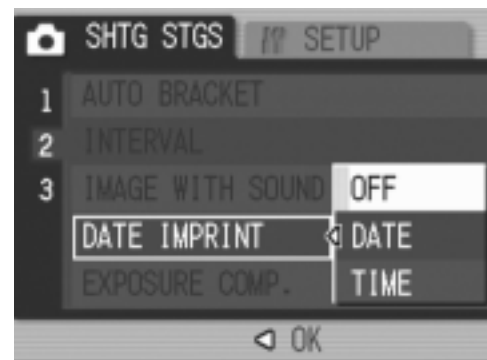

6. **If you pressed the ◀ button in step 5, press also the MENU/OK button.**

The Date Imprint settings are completed.

The shooting setting menu disappears

and the LCD monitor displays .

This setting will be used for shooting until you change it.



## Note

- If the date and time have not been set, DATE IMPRINT cannot be used. First make the date and time settings (P.134).
- DATE IMPRINT cannot be used with movies.
- A thumbnail image is not displayed with a date.

# Changing the Exposure (EXPOSURE COMP.)

The exposure setting allows you to select brightness levels for your shots. Normally, if your subject is centered, backlight compensation is automatically activated, and you can shoot with correct exposure. However, in the following cases, or when you intentionally want to change the exposure, you can change the exposure setting. Exposure can be specified in the range from -2.0 to +2.0. Setting the level higher (+) makes pictures brighter and lower (-) makes pictures darker.

## For Backlighting

When the background is particularly bright, the subject will be dark (underexposure). In this case, set the exposure level higher (+).





## When your subject is whitish

It will turn out entirely dark (underexposure). Set the exposure level higher (+).

## When your subject is darkish

It will turn out entirely bright (overexposure). Set the exposure level lower (-). The same happens when you take photos of people in a spotlight.

To change the setting, use either the Shooting Setting menu or the ADJ. dial. This section explains easy ways with the ADJ. dial. When using the Shooting Setting menu, see "Using the Shooting Setting Menu" ( P.68).

1. **Make sure the camera power is on and turn the mode dial to , P or A.**
2. **Press the ADJ. dial.**
3. **Press the   buttons until the Exposure menu appears.**
4. **Press the   buttons and specify a value.**
5. **Press the MENU/OK button.**









The setting of exposure compensation is completed and the LCD monitor displays the set values.

## Note



- This function cannot be used in Manual Exposure mode.
- When shooting in particularly bright places, you may fail in preventing overexposure. In that case, the [!AE] symbol will be displayed.

# Using Natural and Artificial Lighting (WHITE BALANCE)

Adjust the white balance so that a white subject may be reproduced as white. At purchase, the White Balance is set to "AUTO"; normally you do not need to change the setting, but if the camera is having difficulty determining the white balance when shooting an object of a single color or under several light sources, you can change the setting.

Types of Modes You Can Select		
Symbol	Mode	Description
AUTO	Auto	Make adjustments automatically.
	Daylight	Select when shooting outdoors (Sunny) and White Balance fails to adjust properly.
	Overcast	Select when shooting in cloudy weather or shade and the White Balance fails to adjust properly.
	Tungsten light	Select when shooting under tungsten light and White Balance fails to adjust properly.
	Fluorescent light	Select when shooting under fluorescent light and White Balance fails to adjust properly.
	Manual Setting	Make adjustments manually.
	Detail	Select a setting value from 16 levels including the levels close to the incandescent lamp level, fine weather level, and cloudy weather level.

To change the setting, use either the Shooting Setting menu or the ADJ. dial. This section explains easy ways with the ADJ. dial. When using the Shooting Setting menu, see "Using the Shooting Setting Menu" ( P.68).

- 1. Make sure the camera power is on and turn the mode dial to , P, A or M.**
- 2. Press the ADJ. dial.**  
The camera enters the ADJ. mode.
- 3. Turn the ADJ. dial.**
- 4. Press the ◀▶ buttons until the White Balance menu appears.**
- 5. Press the ▲▼ buttons to select a mode other than .**

You can also press the shutter button in this state.

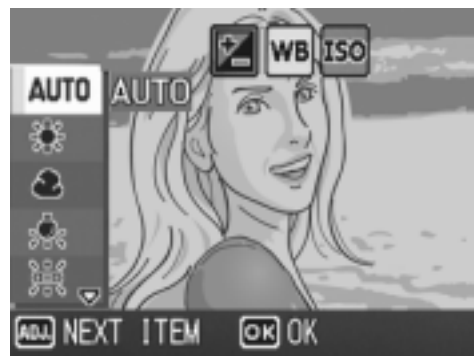

## 6. Press the MENU/OK button.

White Balance settings are completed and the symbol appears on the screen. This setting will be used for shooting until you change it.

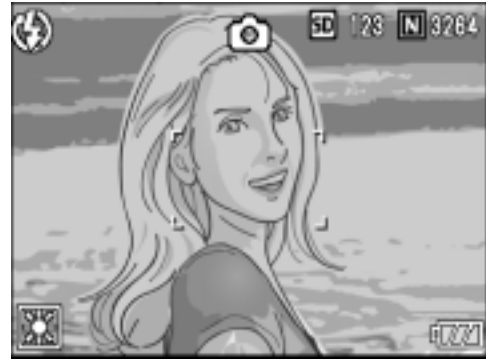

## Setting the White Balance Manually (Manual Setting)

### 1. Make sure the camera power is on and turn the mode dial to , P, A or M.

### 2. Press the ADJ. dial.

The camera enters the ADJ. mode.

### 3. Turn the ADJ. dial.

### 4. Press the buttons until the White Balance menu appears.

### 5. Press the buttons to select (Manual Setting).

### 6. Point the camera at a piece of paper or something white under the lighting conditions for your picture.



### 7. Press the DISP. button.

White Balance is set.



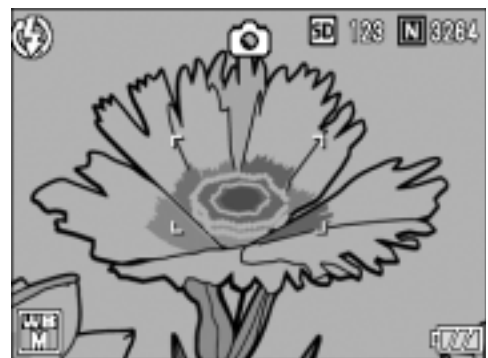

### 8. Press the MENU/OK button.

The setting of white balance is completed and the LCD monitor displays a marking. This setting will be used for shooting until you change it.



If you press the DISP. button in step 7, the screen refreshes to show the White Balance settings made. If the result is not as expected, repeat steps 6 and 7 to change the settings as many times as required.



## Setting the White Balance (Detail)

1. **Make sure the camera power is on and turn the mode dial to , P, A or M.**
2. **Press the ADJ. dial.**  
The camera enters the ADJ. mode.
3. **Turn the ADJ. dial.**
4. **Press the   buttons until the White Balance menu appears.**
5. **Press the   button to select [Detail] and press the DISP. button.**  
The Detail Setting menu appears.



6. **Press the   buttons to select an White Balance.**
7. **Press the MENU/OK button.**
8. **Press the MENU/OK button.**  
The setting of white balance is completed and the LCD monitor displays a marking. This setting will be used for shooting until you change it.

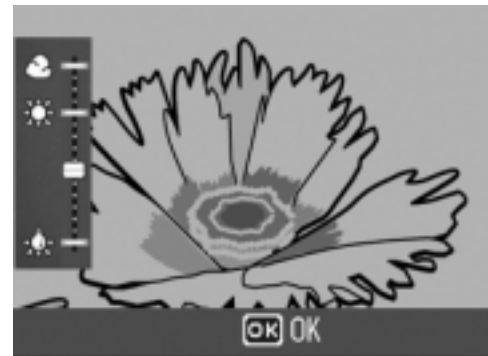

### Note

In Auto Mode, white balance may not be adjusted correctly for a subject that is mostly dark. In this case, add something white as the subject.

### Caution

When shooting with flash, white balance may not be adjusted correctly. In this case, switch to Auto Mode for shooting with flash.



## Changing Sensitivities (ISO SETTING)

The ISO sensitivity indicates how sensitive to light the film is. A greater value means higher sensitivity. High sensitivity is suitable for shooting an object in a dark place or moving fast and suppresses blurring. However, the images become rough.

For higher or lower sensitivity, you can select from the following seven levels: AUTO, ISO64, 100, 200, 400, 800, 1600

When the ISO sensitivity is set to AUTO, the camera automatically varies the sensitivity according to the distance, brightness, and macro settings. Usually, use your camera in AUTO mode.

**1. Make sure the camera power is on and turn the mode dial to , P, A or M.**

**2. Press the MENU/OK button.**

The Shooting Setting menu appears.

**3. Press the  button to select [ISO SETTING] and press the  button.**

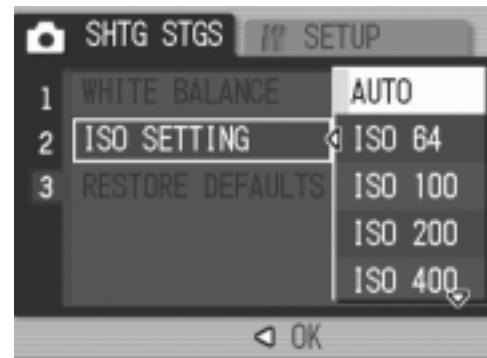

**4. Press the   buttons to select an ISO setting.**

**5. Press the MENU/OK or  button.**

**6. If you pressed the  button in step 5, press also the MENU/OK button.**

Now you have finished ISO sensitivity setting.

The setting of ISO sensitivity is completed and the LCD monitor displays the set values.

This setting will be used for shooting until you change it.



### Note

In Wide-angle Zoom mode, when the ISO Sensitivity is set to Auto, the sensitivity is equivalent to ISO125 with flash or ISO60-160 without flash.

# Returning the Shooting Setting Menu Settings to their Defaults (RESTORE DEFAULTS)

---

To return the Shooting Setting menu settings to their defaults, follow the steps below.

1. Turn the Mode Dial to .
2. Press the MENU/OK button.
3. Press the ▲▼ button to select [RESTORE DEFAULTS] and press the ► button.
4. Make sure that [YES] is selected, and then press the MENU/OK button.

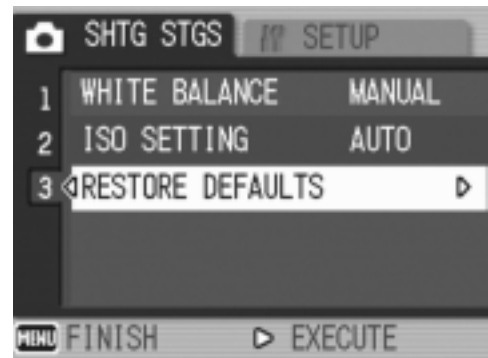

The display indicates the camera is restoring the initial settings; once it is finished, the display returns to the Mode screen.

## Reference

---

For a list of functions whose settings are not cleared by power-off, see P.190.

# Changing Shading for Shooting Text (DENSITY)

You can change the shading of text for shooting in Text Mode of Scene Mode.

You can select from DEEP, NORMAL and LIGHT.

To change the setting, use either the Shooting Setting menu or the ADJ. dial.  
This section explains easy ways with the ADJ. dial.  
When using the Shooting Setting menu, see "Using the Shooting Setting Menu" ( P.68).

1. Turn the Mode Dial to **SCENE**.
2. Press the **▶** button.  
The still image mode selection screen appears.
3. Press the **▲▼** buttons to select an text mode.
4. Press the MENU/OK button.

5. Press the **ADJ.** dial.  
The Text Density menu appears.

6. Press the **▲▼** buttons to select the desired density setting.  
You can also press the shutter button in this state.

7. Press the MENU/OK button.

Text Density settings are completed.  
The Text Density setting value does not appear on the screen. This setting will be used for shooting until you change it.

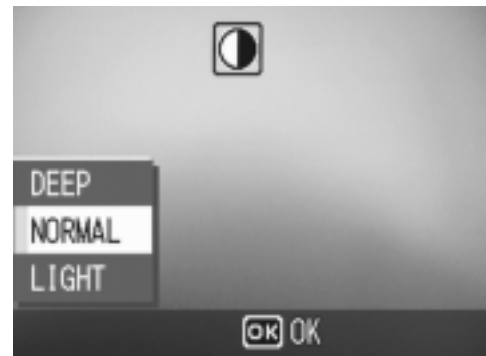

## Reference

For how to shoot text, see P.47.

## Using the AF Target Shift Function

At macro shooting, the AF target shift function allows you to lock the focus (P.40) by using the ▲▼◀▶ buttons on the camera without moving the camera.

This is useful for macro shooting on a tripod with locked focus.

The AF target shift function allows you to shift the cross at the center of the LCD monitor to the subject with the ▲▼◀▶ buttons for focusing.

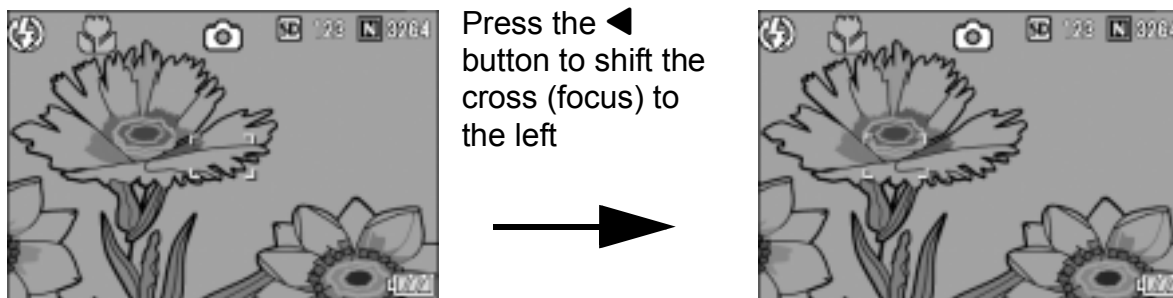

1. **With the camera ready to shoot, press the  button.**

The Macro symbol is displayed at the top of the screen.

2. **Press the ADJ. dial.**
3. **Press the ◀▶ buttons until the AF Target Shift Function screen (cross shown in the figure) appears.**

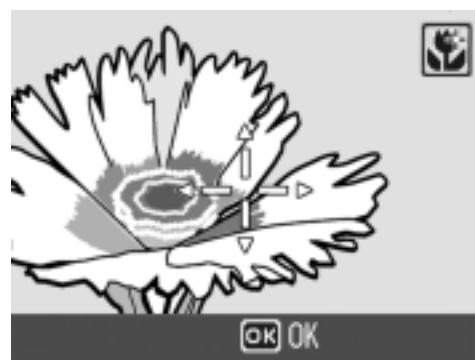

4. **Shift the cross to the subject with the ▲▼◀▶ buttons for focusing.**

5. **Press the MENU/OK button.**

6. **Half-press the shutter button.**

The camera focuses on the cross.

7. **Gently press the shutter button all the way.**



Until you get out of the Macro mode, the AF target shift function automatically focuses the camera on the set position.

# Using the Self-Timer

---

You can set the Self-timer to shoot after either two or ten seconds. A setting of two seconds is useful for preventing camera shake.

**1. Make sure the camera power is on and turn the mode dial to , P, A, M or SCENE.**

**2. Press the  (Self-timer) button.**

The Self Timer mark appears.

The "10" to the right of the symbol indicates the number of seconds. In this case, if you press the shutter button, the camera will shoot after 10 seconds.



**3. Press the shutter release button.**

The focus is locked, the auxiliary light goes on, and the self-timer starts. Once the picture is taken, the self-timer mode is cleared.

## Note

- Each press of the  (Self-timer) button, it selects a function in the following sequence: 10 sec, 2 sec, Self-timer Off, 10 sec, 2 sec.
- Self-timer settings are released when the power is turned off.
- When the self-timer is set to 2 seconds, the AF auxiliary light for self-timer display does not go on.

# Shooting with the Aperture Set (Aperture Priority Mode)

---

To shoot with the aperture fixed, follow the steps below.

Turn the Mode Dial to A (Aperture Priority mode) to set the aperture manually.

When you select the Aperture Priority mode, the camera automatically sets the shutter speed according to the manually set aperture. You can select the aperture from Maximum, Medium, and Minimum.

When Maximum is selected, the subject is emphasized with the background befogged. When Minimum is selected, the shot image is given depth and can be seen clearly from the front to the far back.

To make settings in the Aperture Priority mode, use the up-down dial.

## 1. Turn the Mode Dial to A.

The current F-value is displayed orange at the right end of the LCD monitor.

## 2. Turn the up-down dial to change the F-value.

## 3. Half-press the shutter button.

The shutter speed is determined and displayed on the LCD monitor.

## 4. Gently press the shutter button all the way.

You can press the shutter button all the way without half-pressing it.



### Note

The aperture operation is performed when the shutter button is fully depressed.

# Shooting with the Aperture and Shutter Speed Set (Manual Exposure Mode)

Turning the Mode Dial to M (Manual Exposure mode) allows you to set the shutter speed manually.

If you set the shutter speed, you can shoot at this shutter speed and the camera-set aperture.

You can select a shutter speed from the following:

1/2000	1/1600	1/1250	1/1000	1/800	1/640
1/500	1/400	1/320	1/250	1/200	1/160
1/125	1/100	1/80	1/60	1/50	1/40
1/30	1/25	1/20	1/15	1/13	1/10
1/8	1/6	1/5	1/4	1/3	1/2.5
1/2	1/1.6	1/1.3	1	2	4
8	15	30	60	120	180

If a fast shutter speed is selected, you can shoot a fast-moving substance as if it were stopping momentarily. If a slow shutter speed is selected, you can shoot the trace of a moving substance.

To make settings in the Manual Exposure mode, use the ADJ. dial. To shoot with the shutter speed set manually, follow the steps below.

## 1. Turn the Mode Dial to M.

The current F-value and shutter speed are displayed along with the indicator.



The indicator shows the range from -2EV to +2EV. If this range is exceeded, the indicator turns orange.

If the difference in exposure is within the range of the indicator, the indication on the LCD monitor changes.

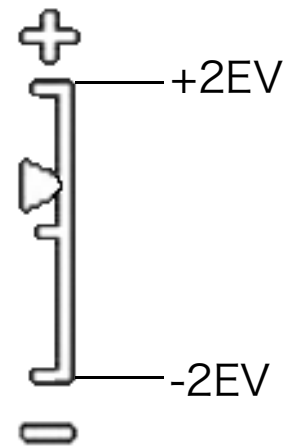

2. Turn the up-down dial to change the F-value and turn the ADJ. dial to change the shutter speed.
3. Half-press the shutter button.
4. Gently press the shutter button all the way.



### Note

- If you select a long exposure, the shutter speed becomes slow and blurring may result. Hold your camera steadily with your hands, a tripod or the like.
- If you select a long exposure, the indication on the LCD monitor disappears during shooting.

### Caution

If the shutter speed is longer than 15 second, the noise reduction function works to increase the time for recording the shot image.



# Shooting with the Aperture and Shutter Speed Changed (Program Shift Mode)

To shoot with the combination of the aperture and shutter speed (program) changed, follow the steps below.

**1. Turn the Mode Dial to P.**



**2. Half-press the shutter button.**

The current combination of the F-value and shutter speed appears on the LCD monitor.



**3. Release your finger from the shutter release button.**

**4. Turn the up-down dial to change the combination of the F-value and shutter speed.**

The combination of the F-value and shutter speed is displayed for about 10 seconds. During this period, change the combination using the up-down dial.



**5. Shoot by half- or full-pressing the shutter button.**



## Note

The program diagram is shown below.

The above diagram is created with the flash mode set to FLASH OFF and the ISO sensitivity to AUTO (ISO 100). The gray portion shows the range where the programmed combination can be shifted. It varies with Ev.

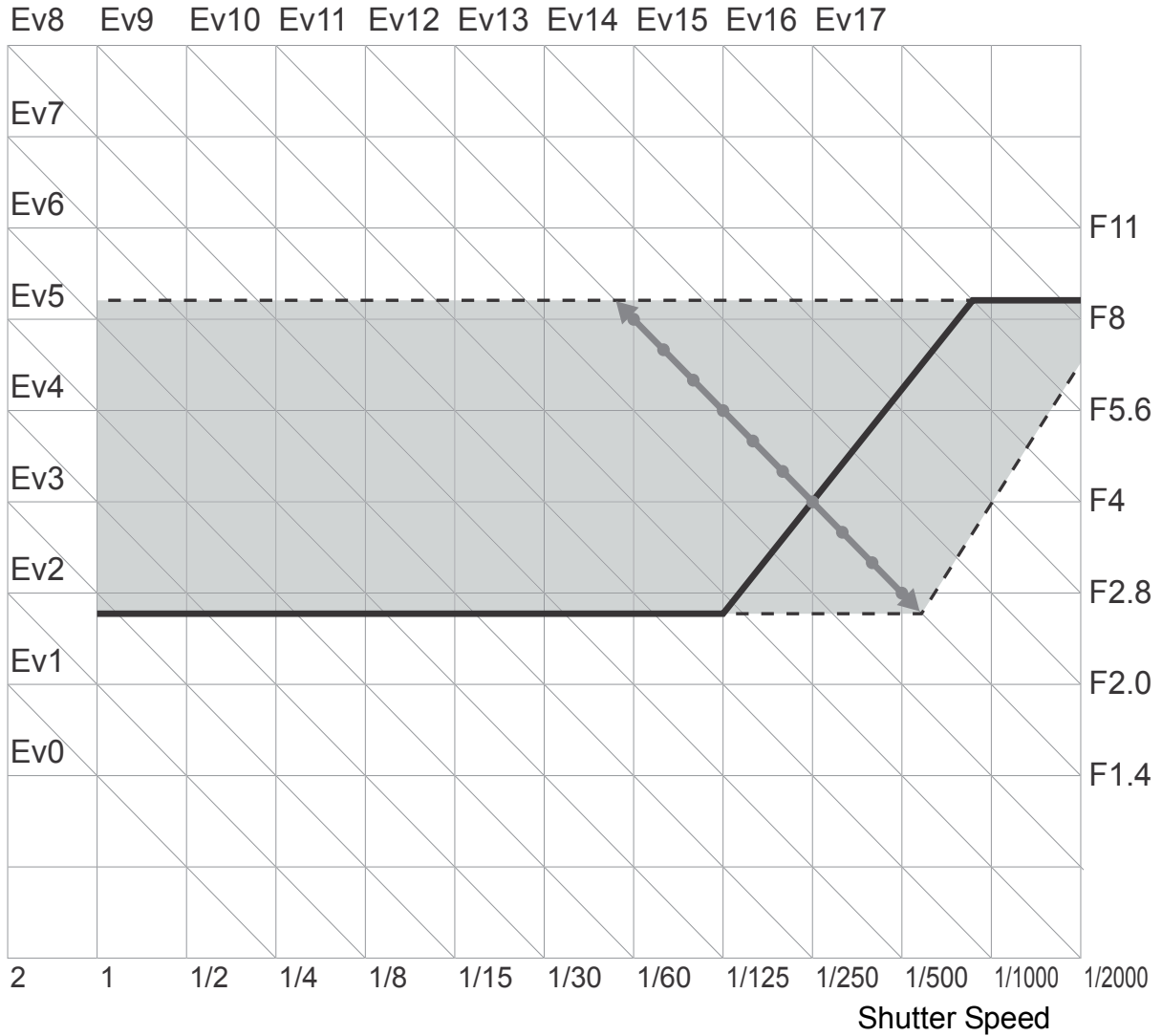

# Shooting with Multi-Shot

If you switch to Multi-Shot, you can shoot consecutive images. Multi-shot can be classified into the following types:

## CONT (Multi-Shot)

As long as you hold the shutter button down, pictures continue to be taken. The still images are recorded one file each, just as in normal shooting.

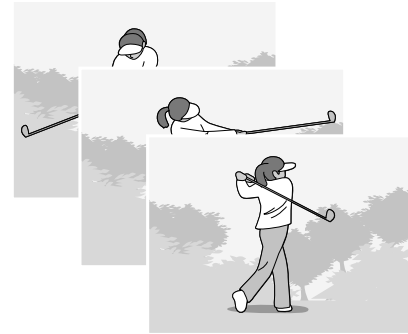

## S (Stream) Multi-Shot

With just one full-press of the shutter, you can take 16 consecutive shots at intervals of 1/7.5 second in about 2 seconds. The 16 still images are grouped together as a set and are recorded as one image file (3264 x 2448 pixels).

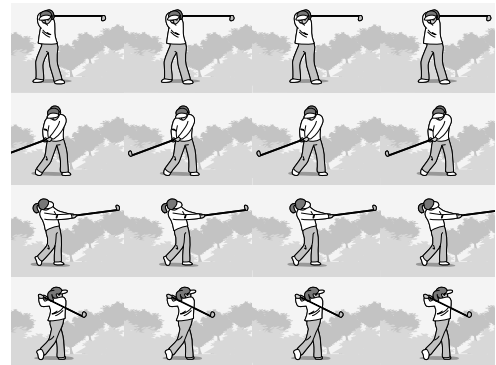

## M (Memory-reversal) Multi-Shot

The camera memorizes the scene while you hold the shutter release button down, and once you release it the previous 2 seconds of shots are recorded.

The 16 still images are grouped together as a set and are recorded as one image file (3264 x 2448 pixels).

2. The camera records for about 2 seconds ahead

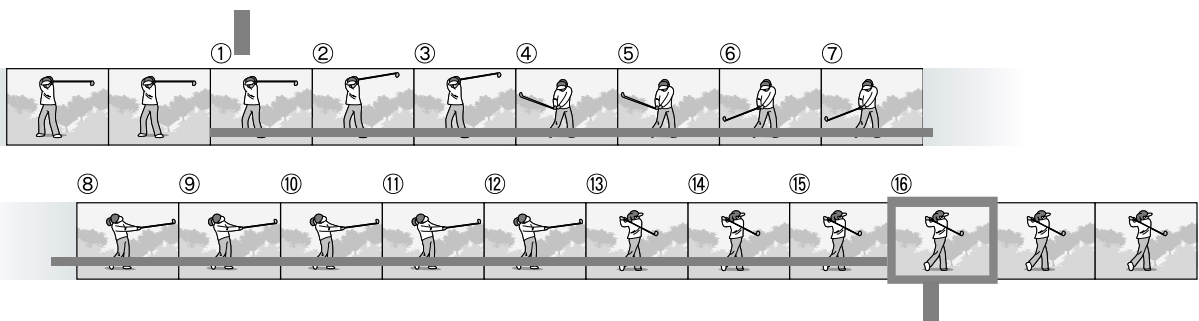

1. If you release the shutter release button here...

## Note

- This function cannot be used when [PIC QUALITY/SIZE] is set to RAW.
- When shooting with S Multi- or M Multi-Shot, the ISO sensitivity is fixed to AUTO even if it is set to 64,100.
- The maximum number of images that can be shot in the Multi-Shot mode depends on the image size setting.
- The numbers of images that can be shot in the Multi-Shot mode with the built-in memory are as shown in the table below.

F3264 (8M)	F3:2 (8M)	N3264 (8M)	N2592 (5M)	N2048 (3M)	N1280 (1M)	N640 (VGA)
4	4	4	4	4	13	13

- When an SD memory card is used to record the images shot in the Multi-Shot mode, images can be recorded normally until the SD memory card becomes full. Once the maximum number of images that can be shot is exceeded, the image recording speed becomes slow. (This depends on the image size setting.)
- When shooting with S Multi-Shot or M Multi-Shot, PIC QUALITY/SIZE can be set to either F3264 or N3264.

**1. Make sure the camera power is on and turn the mode dial to , P, A or M.**

**2. Press the MENU/OK button.**

The Shooting Setting menu appears.

**3. Press the ▼ button to select [CONT] and press the ► button.**

**4. Press the ▲▼ buttons to select [CONT], [SCONT], or [MCONT].**

**5. Press the MENU/OK or ◀ button.**

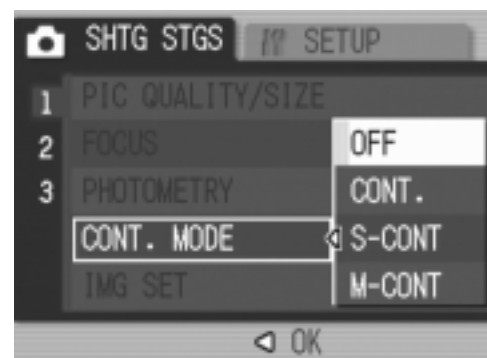

**6. If you pressed the ◀ button in step 5, press also the MENU/OK button.**

The Shooting Setting menu closes and the symbol is displayed at the top of the screen.



## **CONT**

---

### **7. Compose your picture, then press and hold the shutter button.**

As long as you hold the shutter button down, pictures continue to be taken.

### **8. Release your finger from the shutter release button to stop recording.**

To playback consecutive images shot in Multi-Shot mode, turn the camera to playback mode (see P.49) and select the still image with the ◀▶ buttons for playback.

## **SCONT (S Multi-Shot)**

---

### **7. Compose your picture, then press the shutter button.**

16 pictures are taken automatically.

## **MCONT (M Multi-Shot)**

---

### **7. Compose your picture, then press and hold the shutter button.**

The camera memorizes the scene while you hold the shutter release button down.

### **8. Release your finger from the shutter release button.**

The camera stops memorizing and the previous 16 still images (in about 2 seconds) are recorded as one still image.

### **Note**

---

- When you want to return to normal single-shot shooting, follow step 1 through 3, select [OFF] in step 4, and press the MENU/OK button.
- In MCONT mode, if you release the shutter button within 2 seconds from the time you first pressed it, the shots from the time you pressed the shutter until you released it will be recorded (the number of consecutive shots will be less than 16).
- The internal flash is switched to OFF.
- During consecutive image shooting, the LCD monitor is off.

# Viewing an S Multi-Shot or M Multi-Shot Still Image in Enlarged Display Mode

---

While still images (16 frames in a file) taken by SCONT or MCONT are displayed, one of the 16 frames can be displayed in an enlarged view. While viewing an enlarged frame image, you can switch between frames.

To view a shot from S Multi-Shot or M Multi-Shot still images in Enlarged Display Mode, follow the steps below.

**1. Press the  (Playback) button.**

The last shot taken is displayed.

**2. Press the   buttons to display an S Multi-Shot or M Multi-Shot still image.**



**3. Press the  (Enlarged Display) button.**

The first frame of consecutive images is displayed in Enlarged Display Mode.

The shot position bar appears at the lower part of the LCD monitor.

Press the   buttons to feed the shot.

To return to the 16-shot display, press the MENU/OK button.

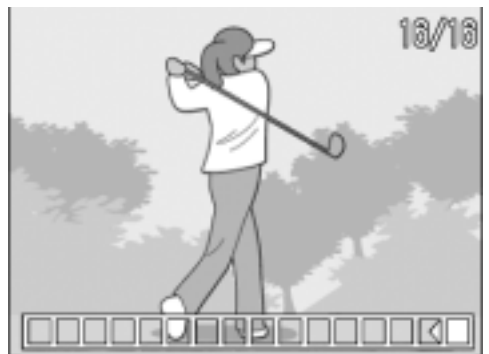

---

 **Note**

Press the DISP. button to turn on or off the bar display at the lower part of the LCD moitor.

---

 **Reference**

For how to shoot images in S Multi-Shot or M Multi-Shot mode, see P.101.

# Shooting/Playing Back Movies

## Shooting Movies

You can shoot movies with sound.

You can select the image size, either 320 x 240 or 160 x 120 pixels. Each movie you shoot is recorded as one AVI file.

1. Turn the Mode Dial to .



2. Press the shutter release button.

The camera starts recording.  
Recording continues until you press the shutter button again.



3. Pressing the shutter button again stops recording.



## **Caution**

---

- While shooting movies, operation sounds may be recorded.
- The maximum recording time per shooting depends on your card. Even within the maximum recording time, some cards may end shooting.

## **Note**

---

- The flash cannot be used.
- When you pressed the shutter button in step 2, the shot comes into focus and the white balance is fixed.
- The remaining recording time may not change uniformly because it is recalculated from the remaining memory capacity during movie recording.

## **Reference**

---

- For how to change the image size for movies, see P.69.
- For the list of shooting setup menu items available in Movie mode, see P.190.

## **Note**

---

The movie recording time depends on the capacity of the SD memory card.  
The recording time is as shown below.

	<b>IN</b>	<b>32MB</b>	<b>64MB</b>	<b>128MB</b>	<b>256MB</b>	<b>512MB</b>	<b>1GB</b>
320 X 240	39 s	44 s	1 min 31 s	3 min 4 s	6 min 7 s	12 min 19 s	23 min 42 s
160 X 120	2 min 26 s	2 min 46 s	5 min 40 s	11 min 27 s	22 min 50 s	46 min 1 s	88 min 31 s



# Playing Back Movies

To playback movies, follow the steps below.

## 1. Press the (Playback) button.

The last shot taken is displayed.

For movies, the first frame is displayed as a still image.

## 2. Move to the movie you want to view using the buttons.

Press the  button to display the next file.







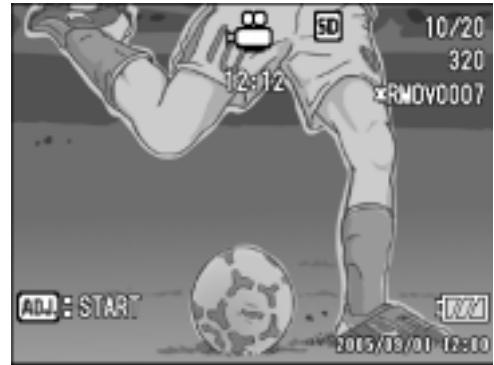

Press the  button to display the previous file.

## 3. Press the ADJ. dial.

Playback begins.

The elapsed playback indicator or the elapsed time is displayed on the LCD Monitor.



Fast Forward	Press the  button during playback.
Rewind	Press the  button during playback.
Pause/Playback	Press the ADJ. dial.
Slow Playback	Keep pressing the  button during pause.
Slow Rewind	Keep pressing the  button during pause.
Next Frame	Press the  button during pause.
Previous Frame	Press the  button during pause.
Volume Adjustment	Press the   buttons during playback.

### Term

#### Movie Frames

A movie frame is also called a frame. Movies consist of many frames whose images appear to be moving when displayed at high speed.

# Recording/Playing Back Sound

## Recording Sound

You can record sound.

Recorded data is stored as a WAV file.

**1. Turn the mode dial to SCENE.**

**2. If the camera is in Text Mode, change it to Voice Memo Mode.**

1. Press the ► button.  
The scene selection screen appears.
2. Press the ▲▼ buttons to select  (Voice Memo).
3. Press the MENU/OK button.



**3. Press the shutter release button.**

Sound recording starts.

**4. Release your finger from the shutter release button to stop recording.**

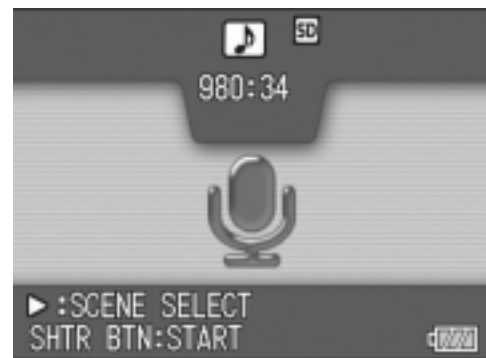

### Note

The voice recording time depends on the capacity of the SD memory card. The table below shows the available recording time.

Internal Memory	32MB	64MB	128MB	256MB	512MB	1GB
56 min 45 s	64 min 36 s	132 min 11 s	267 min 15 s	532 min 36 s	1073 min 00 s	2063 min 25 s

### Caution

When recording sound for a long time, use of the AC adapter (AC-4c) is recommended.

# Playing Back Sound

To playback sounds, follow the steps below.

**1. Press the  (Playback) button.**

The last shot taken is displayed.



**2. Press the   buttons to select a sound file for playback (speaker icon).**

Press the  button to display the next file.





Press the  button to display the previous file.



**3. Press the ADJ. dial.**

Playback begins.



Fast Forward	Press the  button during playback.
Rewind	Press the  button during playback.
Pause/Playback	Press the ADJ. dial.
Volume Adjustment	Press the   buttons during playback.

# Other Functions Available in Playback Mode

## Playback Setting Menu

The Playback menu provides the functions shown in the table below:

Setting	Option	Refer to
SLIDE SHOW	_____	P.111
PROTECT	Select/Deselect 1 FILE, Select/Deselect ALL FILES, Select Multi-files	P.112
DPOF	Select/Deselect 1 FILE, Select/Deselect ALL FILES, Select Multi-files	P.115
RESIZE	1280, 640	P.118
COPY TO CARD	_____	P.119



## Using the Playback Menu

1. Press the  (Playback) button to select the Playback mode.



2. Press the MENU/OK button.  
The Playback menu appears.



3. Press the   buttons to select the desired setting.
4. After selecting a setting item, press the  button.  
Each function screen appears.

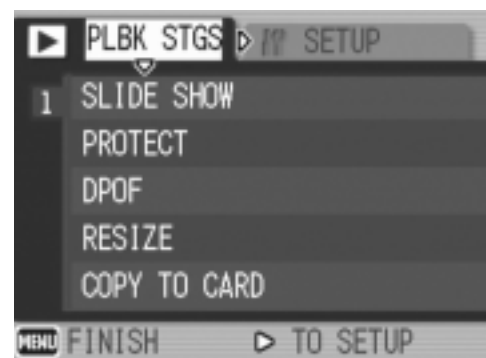

# Showing Photos in Order Automatically (SLIDE SHOW)

---

You can show the recorded still images, movies, and sound files sequentially on the LCD Monitor. This function is called a slide show. To view a slide show, follow the steps below.

**1. Press the  (Playback) button.**

The last shot taken is displayed.

**2. Press the MENU/OK button.**

The Playback menu appears.

**3. Make sure that [SLIDE SHOW] is selected, and then press the  button.**

The slide show starts and files are played back in order.

If you want to stop the slide show in progress, press any button on the camera.

Until stopped, the slide show will repeat itself.

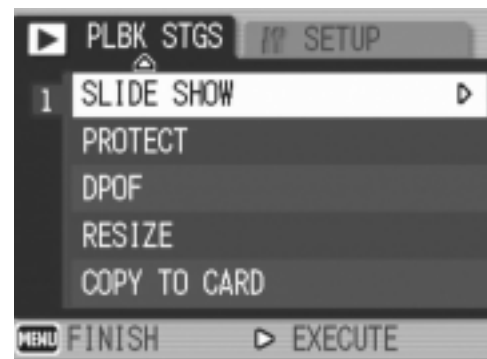

 **Note**

- Still images are displayed for 3 seconds each.
- For movies, not just one frame, but the entire movie you shot is displayed.
- Sound files are also played back.





# Write-protecting Your Images (PROTECT)

You can protect files from being accidentally deleted.

## Caution

Protected files cannot be deleted normally. However, they will be deleted completely if you format the memory where the files are stored.

## Protecting Files

- 1. Press the  (Playback) button.**  
The last shot taken is displayed.
- 2. Press the   buttons to display the file you want to protect.**
- 3. Press the MENU/OK button.**  
The Playback Setting menu appears.
- 4. Press the  buttons to select [PROTECT] and press the  button.**
- 5. Make sure that [1 FILE] is selected, and then press the MENU/OK button.**

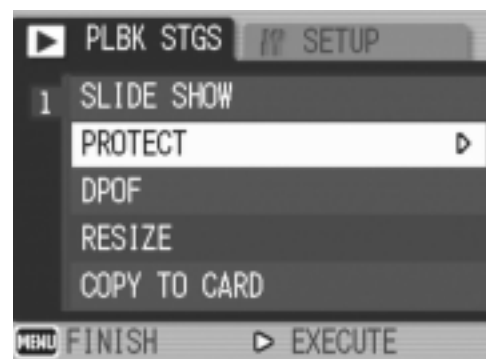





Protection is applied and the Protect symbol appears in the upper-left corner of the screen.



## Protecting All Files

To protect all your files, follow the steps below.

1. Press the  (Playback) button.
2. Press the MENU/OK button.  
The Playback menu appears.
3. Press the  button to select [PROTECT] and press the  button.
4. Press the  button to select [ALL FILES].

5. Make sure that [SELECT] is selected, and then press the MENU/OK button.

Protection is applied and the Protect symbol appears in the upper-left corner of the screen.

To remove protection from all your files, select [CANCEL] in step 5.

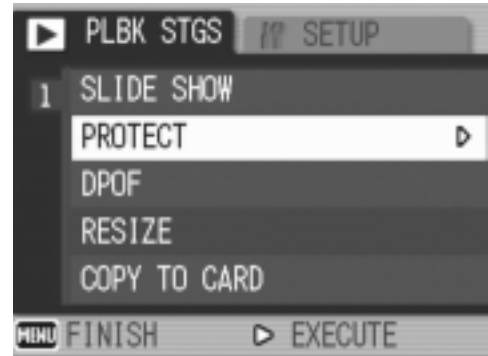

### Note

You can remove protection from all or multiple files at once.

## Protecting Multiple Files at Once

To protect selected files all at once, follow the steps below.

1. Press the  (Playback) button.

2. Press the  (Thumbnail) button twice.





The screen is divided into 12 frames and displays 12 still images at once.

3. Press the     buttons to select the first file of the selection.

4. Press the MENU/OK button.

The Playback menu appears.

5. Press the  button to select [PROTECT] and press the  button.

6. Press the     buttons to select the next file of the selection, and then press the MENU/OK button.

The Protect symbol appears in the upper-right corner of the file.

7. Repeat Step 6 to select all the files you wish to protect.

If you selected a file by mistake, you can deselect by selecting the file and pressing the MENU/OK button again.

8. Press the DISP. button.

The display indicates that the selected images are being processed; once finished, the display returns to the Thumbnail Display screen.

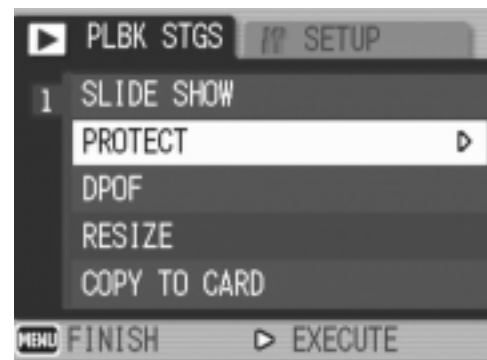

### Note

To remove protection from multiple files, follow the same steps described above to select them and remove protection.

### Reference



For details on thumbnail display, see P.52.



## Using a Printing Service (DPOF)

The still images recorded on an SD Memory Card can be printed out if you take them to a shop that offers a digital camera print service. To use a print service, it is necessary to make settings required for printing. These settings are called DPOF (Dee-Pof) settings. The DPOF setting specifies one print per still image. However, if multiple images are selected for batch setting, you can specify the number of copies to print.

### Setting DPOF for the Still Image Displayed

1. Press the  (Playback) button.
2. Display the still image you want to specify.
3. Press the MENU/OK button.  
The Playback Setting menu appears.
4. Press the  button to select [DPOF] and press the  button.

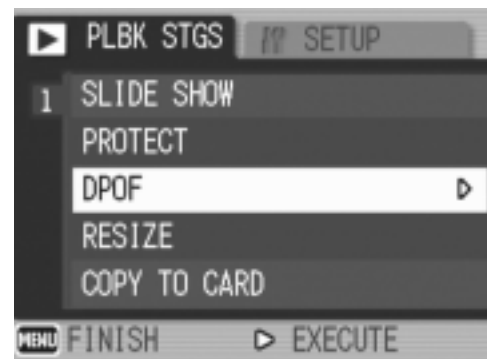

5. Make sure that [1 FILE] is selected, and then press the MENU/OK button.

Once the DPOF setting is made, the DPOF symbol appears in the upper-left portion of the screen.

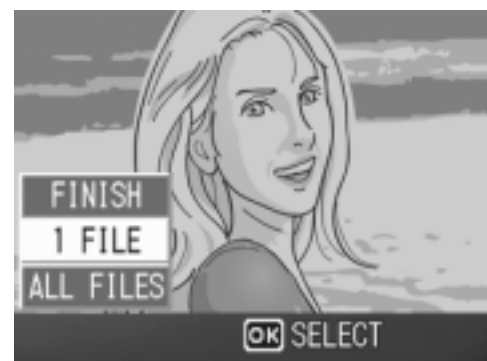





#### Note

- Removing the DPOF setting for one photo at a time is done in the same way as setting it.
- DPOF is set only for the JPEG files among the images shot in RAW mode.

## Setting DPOF for All Still Images

To apply DPOF settings to all your still images, follow the steps below.

1. Press the  (Playback) button.
2. Press the MENU/OK button.  
The Playback menu appears.
3. Press the  button to select [DPOF] and press the  button.
4. Press the   buttons to select [ALL FILES].

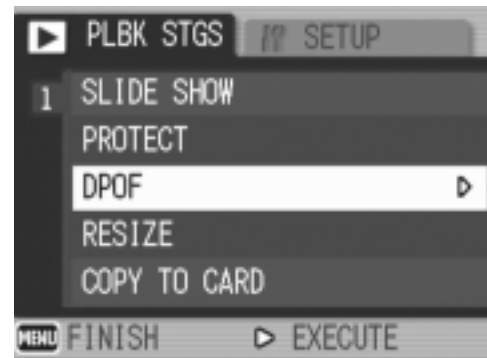

5. Make sure that [SELECT] is selected, and then press the MENU/OK button.

Once the DPOF setting is made, the DPOF symbol appears in the upper-left portion of the screen.

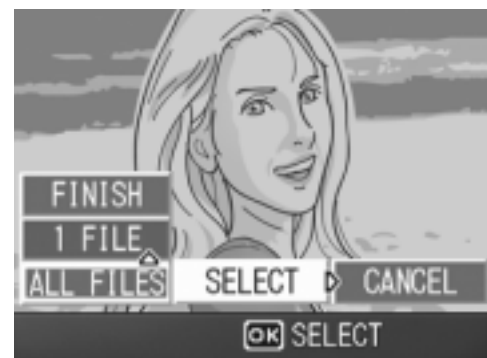



### Note

- To remove the DPOF setting from all your still images, select [CANCEL] in step 5.
- You can remove all or multiple still image DPOF settings at once.

## Setting DPOF for Multiple Still Images

To make the DPOF setting for selected still images all at once, follow the steps below.





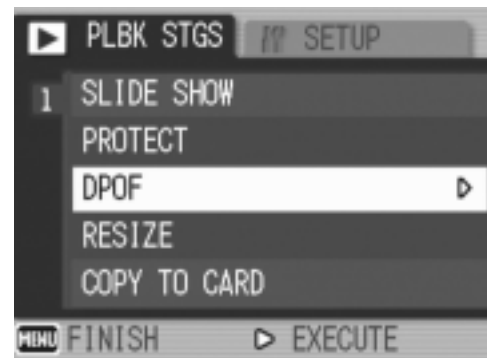

1. Press the  (Playback) button.
2. Press the  (Thumbnail) button twice.  
The screen is partitioned into twelve segments to display the thumbnails of files.
3. Press the  buttons to select the first still image for which you wish to make the DPOF setting.

4. Press the MENU/OK button.

The Playback menu appears.

5. Press the  button to select [DPOF] and press the  button.



6. Press the  buttons to set the number of copies to print.  
Press the  button to increase the number, or the  button to decrease it.
7. Press the  buttons to select the next still image for which you wish to make the DPOF setting.
8. Press the  buttons to set the number of copies to print.  
Press the  button to increase the number, or the  button to decrease it.
9. Repeat Steps 7 and 8 to select all the still images for which you wish to make the DPOF setting.
10. Press the MENU/OK button.

The display indicates that the selected images are being processed; once finished, the display returns to the Thumbnail Display screen.

# Changing the Image Size (RESIZE)

You can reduce the image size of a shot still image to additionally create a file of a different image size.

## Caution





- Still images with voice memos, movies, and images shot in the RAW mode (RAW3264/RAW3:2) cannot be resized.
- The ratio of width to height of the F3:2 image is 3:2. When this image is resized, it is reduced to the ratio of 4:3, with black borders added at the top and bottom of the image.

## Note

The following types of resizing are possible:

Original	Resized	
F3264/F3:2/N3264/N2592/N2048	N1280	N640
N1280	N640	

To change the image size, follow the steps below.

1. Press the  (Playback) button.
2. Press the MENU/OK button.  
The Playback Setting menu appears.
3. Press the  button to select [RESIZE] and press the  button.
4. Press the   buttons to select [1280] or [640].
5. Press the MENU/OK button.  
The image size is changed and the resized still image is displayed.

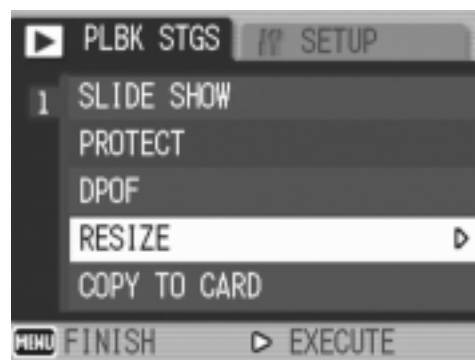

## Reference

For how to change the image size at shooting, see P.69.

# Copying the Contents of Internal Memory to a Memory Card (COPY TO CARD)

---

You can copy all movies, still images, and sound data stored in internal memory onto an SD Memory Card at once.

1. Turn the Camera Off.
2. Insert an SD Memory Card.
3. Turn the camera on.
4. Press the  (Playback) button.

5. Press the MENU/OK button.

The Playback Setting menu appears.

6. Press the  button to select [COPY TO CARD] and press the  button.

The display indicates copying is in progress; once finished, the display returns to the playback screen.

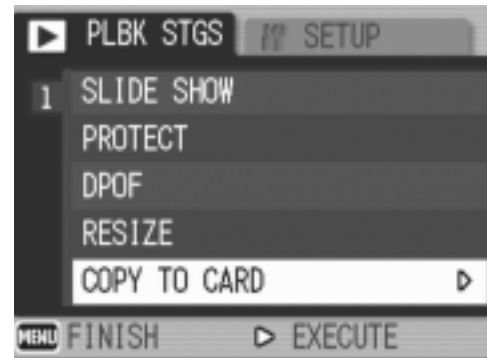

## Note

- If the capacity of the SD Memory Card you are copying to is insufficient, a message will be displayed indicating there is not enough capacity. To copy only the number of shots that will fit into the available capacity, select [YES] and then press the MENU/OK button. To cancel copying, select [NO] and then press the MENU/OK button.
- It is not possible to copy from SD Memory Card to internal memory.



# Chapter 3

## Changing Camera Settings

Changing Camera Settings ..... 122

# Changing Camera Settings

## SETUP Menu

You can change camera settings by displaying the SETUP menu from the Shooting Setting menu (see P.67) or Playback Setting menu (see P.110). The SETUP menu enables you to set the items listed in the table below.

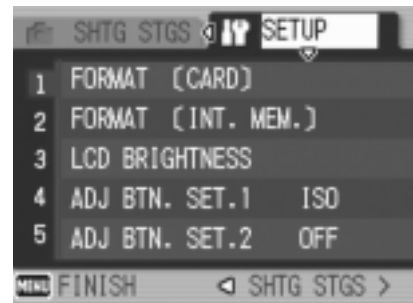

\*Among the choices listed in the table below, default values at purchase are enclosed in [ ].

Setting	Option	Refer to
FORMAT [CARD]	_____	P.124
FORMAT [INT. MEM.]	_____	P.125
LCD BRIGHTNESS	_____	P.126
ADJ. BTN. SET. 1 ADJ. BTN. SET. 2	[OFF], ISO, QUALITY, FOCUS, IMG SET, METERING, CONT MDE, AUTO BKT, WITH SND	P.127
AUTO POWER OFF	OFF, [1], 5, 30 Minutes	P.128
BEEP SOUND	[ALL], SHUTTER	P.129
OPE. ALERT VOL.	OFF (□□□) , Small (■□□) , [Medium] (■■□) , Large (■■■)	P.130
LCD CONFIRM.	OFF, 0.5, [1], 2, 3 Seconds	P.131
SEQUENTIAL NO.	[ON], OFF	P.132
DATE SETTINGS	_____	P.134
LANGUAGE	日本語 , [ENGLISH], DEUTSCH, FRANÇAIS, ITALIANO, ESPAÑOL, 简体中文, 繁体中文, 한국어	P.135
VIDEO OUT MODE	[NTSC], PAL	P.136
SHTG STGS WARNG.	[ON], OFF	P.137
USB CONNECTION	MASS STR, [ORIGINAL]	P.138
ENLGE PHOTO ICON	[OFF], ON	P.142
COLOR SPACE SET	[sRGB], Adobe RGB	P.143
AF AUX. LIGHT	[ON], OFF	P.145
DIGITAL ZOOM	ON, [OFF]	P.146
ZOOM BTN. SET.	OFF, [EXPO. CMP], WHT. BAL.	P.147
REG. MY SETTINGS	SETTING1, SETTING2	P.148
START SETTINGS	[OFF], SETTING1, SETTING2	P.149



# Using the SETUP Menu

To display and use the Setup menu, follow the steps below.

## Note

For some functions, the choice selection method may not be as explained here. For detailed operation, see the explanation of each function.

### 1. Press the MENU/OK button.

The Shooting Setting menu (or the Playback menu) appears.

### 2. Press the button.

The setup menu appears.



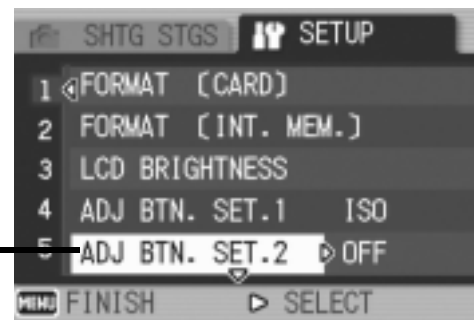

### 3. Press the buttons to select the desired setting.

The setting items are provided on 5 screens.

When the  button is pressed at the bottom item, the next screen appears.



#### To select a screen by screen number:

1. Press the  button to select a screen number on the left of the screen.
2. With the screen number selectable, press the   buttons to switch between screens.
3. After selecting the screen, press the  button to return to the setting item selection step.

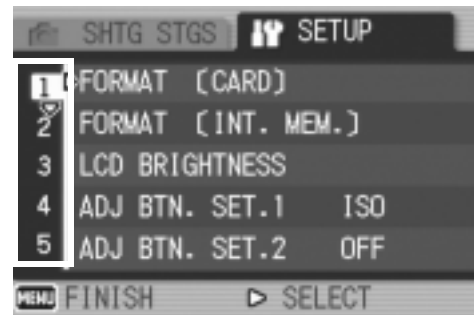

### 4. After selecting a setting item, press the button.

Choices for the setting item are displayed.

### 5. Press the buttons to select a choice.

### 6. Press the MENU/OK or button.

### 7. If you pressed the button in step 6, press also the MENU/OK button.

The menu disappears and the camera becomes ready for shooting and playing back.

# Formatting the SD Memory Card (FORMAT [CARD])

---

If the error message "This card cannot be used" is displayed, or if you have formatted a card with a computer or some other device, it will be necessary to format the SD Memory Card prior to use. Formatting is the process of preparing a card so image data can be written on it.

## Caution

---

If you format a card that still has images stored on it, the images will be lost.

## Reference

---

For how to format internal memory, see P.125.

To format a card, follow the steps below.

### 1. Display the setup menu.

For detailed operation, see P.123.

### 2. Press the ▼ button to select [FORMAT [CARD]] and press the ► button.

A screen appears to confirm formatting.

### 3. Press the ◀▶ button to select [YES] and then press the MENU/OK button.

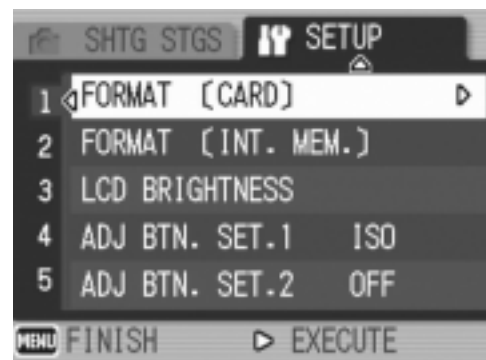

Formatting starts. When it is done, the display returns to the SETUP menu.

If no SD Memory Card is inserted, a message will be displayed.

After turning the power off, load an SD Memory Card and repeat the formatting process again.

## Note

---

### Protecting your images from being deleted

If you move the card's write-protection switch to LOCK, your still images cannot be accidentally erased and the card cannot be formatted.

If you release the protection (by returning the switch to its original position), it is once again possible to erase images and format the card.

# Formatting Internal Memory (FORMAT [INT. MEM.])

If an error message "Format the internal memory" is displayed, it will be necessary to format the internal memory prior to use.

## Caution

Formatting the internal memory erases all of the images recorded in the memory. If you have images that you do not want to erase stored on the internal memory, please contact the Ricoh Service offices prior to formatting it.

To format internal memory, follow the steps below.

- 1. Display the setup menu.**  
For detailed operation, see P.123.
- 2. Press the ▼ button to select [FORMAT [INT. MEM.]] and press the ► button.**  
A screen appears to confirm formatting.
- 3. Press the ◀► buttons to select [YES] and then press the MENU/OK button.**  
Formatting starts. When it is done, the display returns to the SETUP menu.

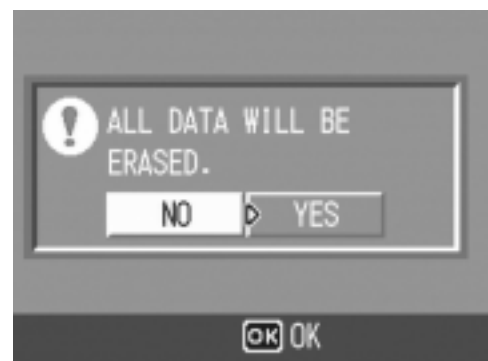
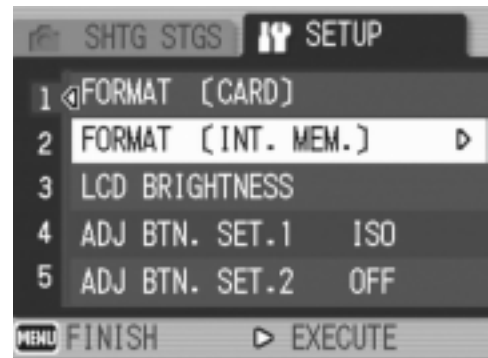

# Adjusting the Brightness of the LCD Monitor (LCD BRIGHTNESS)

---

To adjust the brightness of the LCD Monitor, follow the steps below.

## 1. Display the setup menu.

For detailed operation, see P.123.

## 2. Press the ▼ button to select [LCD BRIGHTNESS] and press the ► button.

The LCD Brightness Adjustment bar appears.



## 3. Press the ▲▼ buttons to adjust the brightness.

Moving it to the ☀ side makes it darker.

Moving it to the 🌙 side makes it brighter.

The brightness of the screen behind the bar changes as you alter the setting.



## 4. When you attain the desired brightness, press the MENU/OK button.

The display returns to the SETUP screen.

This setting will be used until you change it.

### Note

When shooting, keep pressing the DISP. button maximizes the LCD brightness.  
When the brightness is at the maximum, keep pressing the DISP. button restores the brightness set using the [LCD BRIGHTNESS] option.

# Setting a Function to the ADJ. dial (ADJ BTN.SET. 1/2)

The ADJ. dial allows you to display the exposure correction screen and white-balance setting screen with fewer button operations.

Functions that can be displayed by pressing the ADJ. dial can be assigned to [ADJ. BTN. SET. 1] and [ADJ. BTN. SET. 2].

Possible Settings	(Refer to)
OFF *Setting 2 upon purchase	-
ISO *Setting 1 upon purchase	P.91
QUALITY (PIC/QUALITY)	P.69
FOCUS	P.74
IMG SET	P.78
METERING	P.77
AUTO BKT	P.80
CONT MDE	P.101
WITH SND	P.85

To assign a function to either [ADJ. BTN. SET. 1] or [ADJ. BTN. SET. 2], follow the steps below.

## 1. Display the setup menu.

For detailed operation, see P.123.

## 2. Press the ▼ button to select [ADJ. BTN. SET. 1] or [ADJ. BTN. SET. 2], and press the ► button then.

## 3. Press the ▲▼ buttons to select the desired setting.

## 4. Press the MENU/OK or ◀ button.

## 5. If you pressed the ◀ button in step 4, press also the MENU/OK button.

This setting will be used until you change it.

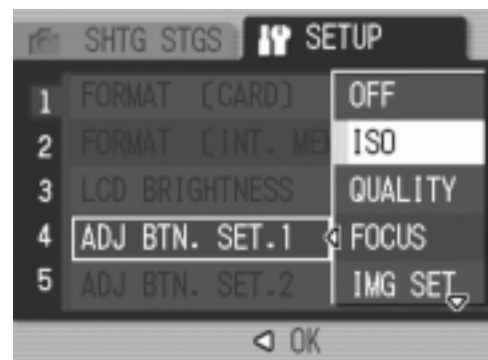

## Reference

For how to use the ADJ. dial, see P.65.

# Changing Auto Power-Off Settings (AUTO POWER OFF)

If you do not operate the camera for the set period of time, it will shut off automatically (Auto Power-off) to conserve battery power. At the time of purchase, Auto Power-Off is set to one minute, but you can change this setting.

Possible Settings
OFF (The Auto Power-Off function does not work)
1 Minute *Setting upon purchase
5 Minutes
30 Minutes

To change the Auto Power-Off setting, follow the steps below.

## 1. Display the setup menu.

For detailed operation, see P.123.

## 2. Press the ▼ button to select [AUTO POWER OFF] and press the ► button.

## 3. Press the ▲▼ buttons to select the desired setting.

## 4. Press the MENU/OK or ◀ button.

## 5. If you pressed the ◀ button in step 4, press the MENU/OK button.

This setting will be used until you change it.

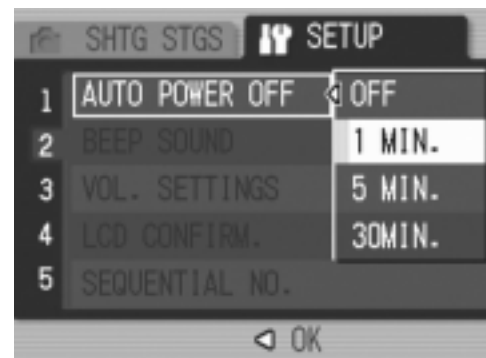

### Note

- To continue on using the camera after auto power-off, press the Power button to turn the camera on again. Keep pressing the Playback button for more than one second also turns on the camera, allowing you to use the camera in Playback Mode.
- The Auto Power-off function does not work when the camera is connected to a computer.
- When shooting with Interval Shooting, settings made here are not valid and Auto Power-Off does not work.

# Changing the Beep Sound Setting (BEEP SOUND)

During operation, the camera generates four types of sounds: start sound, shutter release sound, focus sound, and beep sound.

- Start sound : Sound when the camera power is turned on.
- Shutter release sound : Sound when the shutter button is pressed.
- Focus sound : When the focus is set, the camera generates the focus sound.
- Beep Sound : If an impossible operation is attempted, the camera generates the beep sound.

Possible Settings
SHUTTER (Shutter release sound, Beep Sound)
ALL (all sounds on) *Setting upon purchase

To change the beep sound settings, follow the steps below:

- 1. Display the setup menu.**  
For detailed operation, see P.123.
- 2. Press the ▼ button to select [BEEP SOUND] and press the ► button.**
- 3. Press the ▲▼ buttons to select the desired setting.**
- 4. Press the MENU/OK or ◀ button.**
- 5. If you pressed the ◀ button in step 4, press also the MENU/OK button.**  
This setting will be used until you change it.

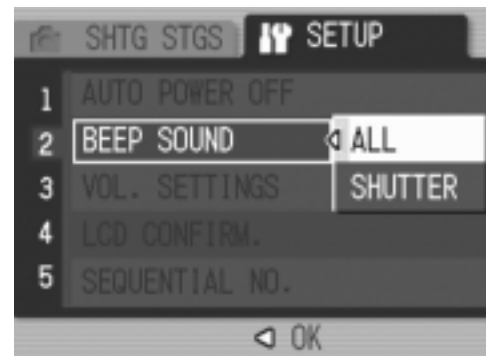

## Reference

For how to adjust volume, see P.130.

# Changing the Beep Sound Volume (VOL. SETTINGS)

The beep sound volume can be changed.

Possible Settings	
<input type="checkbox"/> <input type="checkbox"/> <input type="checkbox"/>	(Mute)
<input checked="" type="checkbox"/> <input type="checkbox"/> <input type="checkbox"/>	(Small)
<input checked="" type="checkbox"/> <input checked="" type="checkbox"/> <input type="checkbox"/>	(Medium) *Setting upon purchase
<input checked="" type="checkbox"/> <input checked="" type="checkbox"/> <input checked="" type="checkbox"/>	(Large)

To change the beep sound volume, follow the steps below:

## 1. Display the setup menu.

For detailed operation, see P.123.

## 2. Press the ▼ button to select [VOL. SETTINGS] and press the ► button.

## 3. Press the ▲▼ buttons to select the desired setting.

## 4. Press the MENU/OK or ◀ button.

## 5. If you pressed the ◀ button in step 4, press also the MENU/OK button.

This setting will be used until you change it.





# Changing Image Confirmation Time (LCD CONFIRM.)

Immediately after pressing the shutter button, the still image taken is displayed for a moment so you can check it.

At purchase, Confirmation Time is set to one second, but this can be changed.

Possible Settings
OFF (Photo not displayed for confirmation)
0.5 Second
1 Second *Setting upon purchase
2 Seconds
3 Seconds

To change Confirmation Time, follow the steps below.

## 1. Display the setup menu.

For detailed operation, see P.123.

## 2. Press the ▼ button to select [LCD CONFIRM.] and press the ► button.

## 3. Press the ▲▼ buttons to select the desired setting.

## 4. Press the MENU/OK or ◀ button.

## 5. If you pressed the ◀ button in step 4, press also the MENU/OK button.

This setting will be used until you change it.

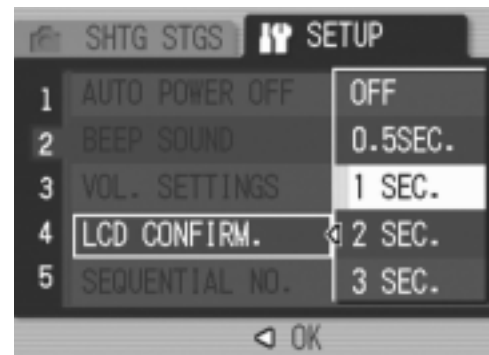

# Changing File Name Settings (SEQUENTIAL NO.)

When you shoot a still image, it is stored on an SD Memory Card or in internal memory, with a consecutively numbered file name automatically assigned.

When you are switching SD Memory Cards, you can set your camera to continue consecutive numbering from the previously loaded SD Memory Card.

Possible Settings	
ON (Continue numbering) *Setting upon purchase	File names will be automatically assigned to still images you take, in the format of "R" followed by 7 digits, from R0010001.jpg to R9999999.jpg. With this setting, even when one SD Memory Card is switched with another, consecutive file numbering from the previous card is continued.
OFF (Do not continue numbering)	Every time a new card is loaded, file numbering is assigned, from RIMG0001.jpg to RIMG9999.jpg. If numbering exceeds RIMG9999, further recording is not possible

To make changes to file numbering, follow the steps below.

## 1. Display the setup menu.

For detailed operation, see P.123.

## 2. Press the ▼ button to select [SEQUENTIAL NO.] and press the ► button.

## 3. Press the ▲▼ buttons to select the desired setting.

## 4. Press the MENU/OK or ◀ button.

## 5. If you pressed the ◀ button in step 4, press also the MENU/OK button.

This setting will be used until you change it.

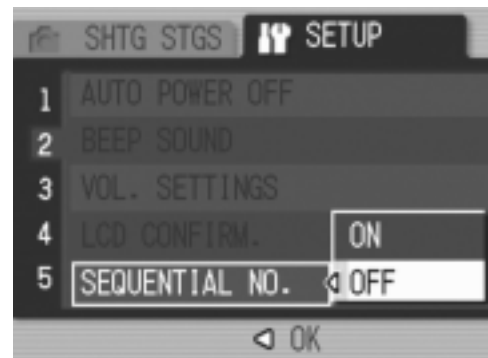



## Note

- When you are recording to internal memory, file names are assigned just as when [SEQUENTIAL NO.] is set to [OFF].
- When transferring images to a computer using RICOH Gate La (P.161), designating a file name same as the one that already exists in the destination folder, the file is renamed before saving to avoid overwrite problems.
- When an image has been transferred to a computer using a mass storage (P.164), it is saved as a file named "RIMG\*\*\*\*.jpg" (\*\*\*\* indicates the number of the image) even if [SEQUENTIAL NO] is set to ON.
- When RIMG9999 is reached, no more files can be saved. In this case, move image data from the SD memory card to the built-in memory of the computer or a storage medium, and then format the SD memory card.
- The name of the file to be recorded varies with the setting of [COLOR SPACE SETTING] in the SETUP menu.

Consecutive numbering	Value of COLOR SPACE setting	
	sRGB	AdobeRGB
ON (Continue numbering)	R0010001.jpg	_0010001.jpg
OFF (Do not continue numbering)	RIMG0001.jpg	_RIMG0001.jpg

# Setting the Date and Time (DATE SETTINGS)

You can take still images with the time or date stamped onto the picture.

The date/time setting on the SETUP menu is explained here.

## 1. Display the setup menu.

For detailed operation, see P.123.

## 2. Press the ▼ button to select [DATE SETTINGS] and press the ► button.



## 3. Press ▲▼◀▶ to set the year, month, date and time.

If you hold down the ▲ or ▼ button, you can increase/decrease the value quickly.

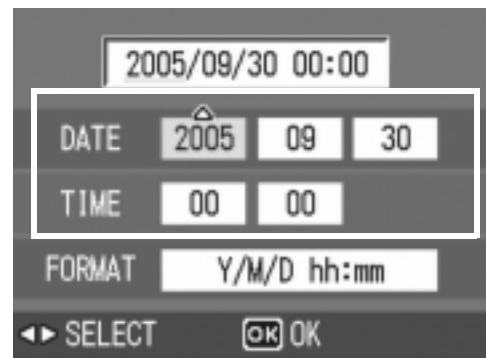

## 4. In [FORMAT], choose the date and time format.

## 5. Check the display on the bottom of the screen and then press the MENU/OK button.

Once you have set the date and time, the display returns to the Setup menu.

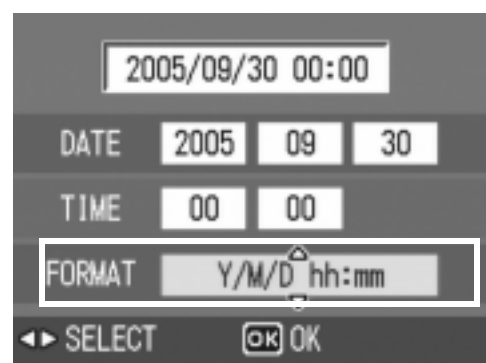

### Note

- If the batteries are removed for more than one week, the date and time settings will be lost. These settings must be made again.
- To retain the date and time settings, load a fully charged battery in the camera for more than two hours.

# Changing the Display Language (LANGUAGE/ 言語 )

You can change the language displayed on the LCD Monitor.

Possible Settings
日本語 (Japanese)
ENGLISH (English) *Setting upon purchase
DEUTSCH (German)
FRANÇAIS (French)
ITALIANO (Italian)
ESPAÑOL (Spanish)
簡体中文 (Simplified Chinese)
繁体中文 (Traditional Chinese)
한국어 (Korean)

To change the display language, follow the steps below.

## 1. Display the setup menu.

For detailed operation, see P.123.

## 2. Press the ▼ button to select [LANGUAGE/言語] and press the ► button.

The language selection screen appears.



## 3. Press the ▲▼◀▶ buttons to select the desired setting.

## 4. Press the MENU/OK button.

This setting will be used until you change it.



# Changing the Playback Method for Viewing on TV (VIDEO OUT MODE)

---

You can view your still images and movies on a television screen by connecting your camera to a television with the AV cable that came with your camera.

Your camera is set to NTSC video format (used in Japan and other countries) for use with television equipment, etc. If the equipment you want to connect to uses PAL format (used in Europe and elsewhere), then switch your camera to PAL format before connecting.

Possible Settings
NTSC *Setting upon purchase
PAL

To change the playback format, follow the steps below.

## 1. Display the setup menu.

For detailed operation, see P.123.

## 2. Press the ▼ button to select [VIDEO OUT MODE] and press the ► button.

## 3. Press the ▲▼ buttons to select the desired setting.

## 4. Press the MENU/OK or ◀ button.

## 5. If you pressed the ◀ button in step 4, press also the MENU/OK button.

This setting will be used until you change it.



### Note

Connecting the AV cable to the camera turns off the LCD monitor display.

### Reference

For how to view still images on your television screen, see P.54.

# Displaying a Setting Change Warning (SHTG STGS WARNG.)

You can set the icon of a changed function to blink or a warning message indicating a change will be displayed at power-on for about 5 seconds if the initial settings are changed for the following functions.

- White Balance
- Focus
- ISO Setting
- Exposure Comp.

If you operate a camera button while an icon is blinking, the icon stops blinking and lights steadily.

If you operate a camera button during a warning message display, the message disappears.

Possible Settings
OFF
ON *Setting upon purchase

To set whether to enable (ON) or disable (OFF) the shooting setting alert, follow the steps below.

## 1. Display the setup menu.

For detailed operation, see P.123.

## 2. Press the ▼ button to select [SHTG STGS WARNG.] and press the ► button.

## 3. Press the ▲▼ buttons to select the desired setting.

## 4. Press the MENU/OK or ◀ button.

## 5. If you pressed the ◀ button in step 4, press also the MENU/OK button.

This setting will be used until you change it.

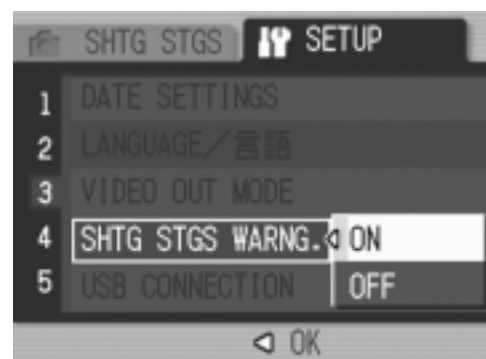

# Changing the USB Communication System (USB Connection)

If the USB communication system is changed (by selecting [MASS STR] at [USB CONNECTION] on the Setup menu), files in the camera can be browsed and transferred from the camera to your computer through the USB cable without installing the accessory application or USB driver.

Usually, select [ORIGINAL]. When [ORIGINAL] is set, you can transfer images to your computer using the supplied RICOH Gate La.

Mode	Mass Storage	Original
Download Method	The SD memory card or built-in memory of the camera can be operated directly as an external drive for file processing.	RICOH Gate La allows automatic transfer to your computer. The mounter allows transfer to your computer. (Mac OS)
Installation from Caplio CD-ROM	Unnecessary	Necessary
Supported OS		
Windows 98/98 SE	X	○
Windows 2000 Professional	○	○
Windows Me	○	○
Windows XP Home Edition	○	○
Windows XP Professional	○	○
Mac OS 8.6	X	○
Mac OS 9.0 to 9.2.2	○	○
Mac OS X 10.1.2 to 10.4	○	○
For those:	Familiar with OS file operations Not willing to install a USB driver or other	Willing to automate downloading to a computer Using Windows 98/98 Second Edition Using Mac OS 8.6

## Caution

- At [MASS STR], RICOH Gate La cannot be used for image transfer.
- At [MASS STR], files can only be read from the camera and cannot be written into or deleted from the camera.
- For direct printing on a printer supporting both Direct Print and PictBridge, select [ORIGINAL] at [USB CONNECTION].



To change the USB communication system, follow the steps below:

**1. Display the setup menu.**

For the operating procedure, see P.123.

**2. Press the ▼ button to select [USB CONNECTION] and press the ► button.**

**3. Press the ▲▼ button to select a value.**

**4. Press the MENU/OK or ◀ button.**

**5. If the ◀ button was pressed in Step 4, press the MENU/OK button.**

These settings are used until they are changed the next time.



 **Reference**

For how to transfer images using RICOH Gate La, see P.161.

To transfer images in Mass Storage Mode, follow the steps below:

1. Change [USB CONNECTION] to [MASS STR] on the Setup menu.
2. Make sure that the camera power is off.
3. Connect the accessory USB cable to a USB port of your computer.
4. Connect the USB cable to the USB terminal of the camera.

The camera power becomes on.  
Your computer automatically reads a file necessary for recognizing the camera as a drive.

After this preparation, the camera is displayed as a drive at My Computer (Windows) or Desktop (Macintosh).



Example of the Windows XP screen

5. From the displayed drive, copy a file to the desired location.

The figure at right shows the folder configuration in a drive.

When the contents of the built-in memory are displayed, the drive name is RICOHDCI.

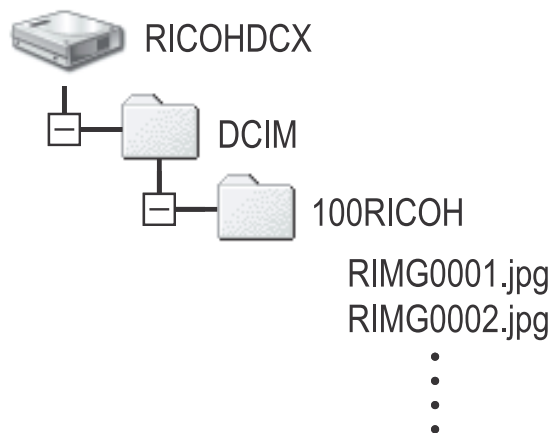

### Caution

- During transfer, do not disconnect the USB cable.
- If a file with the same name already exists at the destination, it is overwritten. If you do not want the file to be overwritten, rename the file or transfer images to another folder.

### Note

When a SD memory card is inserted, its files are displayed. Otherwise, files in the built-in memory are displayed.

## Disconnecting the Camera from Your Computer (Windows)

This display is an example for Windows XP. The terms are different for other OS but the operations are the same.

1. Click the **Remove Hardware Safely** icon at the right end of the task bar.
2. Select **[USB Large-capacity Storage Device]** and click **[Stop]**.
3. Check that **[USB Large-capacity Storage Device]** is selected and click **[OK]**.
4. Click **[OK]**.
5. Unplug the USB cable.



## Disconnect the Camera from Your Computer (Macintosh)

1. Put the displayed drive in the Recycle Bin.
2. Unplug the USB cable.

## Enlarging Icon Display (ENLGE PHOTO ICON)

---

Icons on the shooting screen are enlarged.

Under this setting, the following icons are enlarged:

- Flash
- Macro Shooting
- Self Timer
- White Balance
- Focus
- Exposure Compensation
- ISO Sensitivity

If icons are enlarged, the following items are not displayed:

- Zoom Bar/Focus Bar
- Date/Time
- Image Settings

To enlarge icons on the shooting screen, follow the steps below:

### 1. Display the setup menu.

For the operating procedure, see P.123.

### 2. Press the ▼ button to select [ENLGE PHOTO ICON] and press the ► button.

### 3. Press the ▲▼ buttons to select [ON].

### 4. Press the MENU/OK or ◀ button.

### 5. If the ◀ button was pressed in Step 4, press the MENU/OK button.

Now you have finished the shooting icon enlargement setting.

These settings are used until they are changed the next time.



## Setting the Color Space (COLOR SPACE SET)

You can select a color space between sRGB (a standard color space used in the digital world) and Adobe RGB (a color space wider than sRGB).

Adobe RGB supported by this camera is compatible with the color space that Adobe Systems Inc. uses for image editing applications such as Photoshop by default.

### 1. Display the **SETUP** menu.

For the operating procedure, see P.123.

### 2. Press the ▼ button to select **[COLOR SPACE SET]**, and then press the ► button.



### When selecting [sRGB]

### 3. Press ▲▼ buttons to select [sRGB].

### 4. Press the MENU/OK or ◀ button.

### 5. If you pressed the ◀ button in step 4, press the MENU/OK button.

## When selecting [AdobeRGB]

**3. Press the ▲▼ buttons to select [AdobeRGB].**

**4. Press the MENU/OK or ◀ button.**

A confirmation message appears to ask whether you are certain to select Adobe RGB.

**5. If you pressed the ◀ button in step 4, press the MENU/OK button.**

**6. Press the ◀▶ buttons to select [YES], and then press the MENU/OK button.**

Now you have completed color space setting.  
This setting will be used until you change it.



### Caution

---

- Adobe RGB is intended for commercial printing, so it is not suitable for common print services and home printers. Adobe RGB covers a color space wider than that of sRGB. In an environment not complying with Adobe RGB, however, images are displayed/printed in faint colors.
- Without the application software that can reproduce the Adobe RGB color space correctly, correct color reproduction will fail.

# Setting the AF Auxiliary Light (AF AUX. LIGHT)

You can set whether to set off the AF auxiliary lamp when shooting in the Auto Focus mode.

When ON is selected, the AF auxiliary lamp goes on to measure the focal distance before shooting as required.

## 1. Display the setup menu.

For the operating procedure, see P.123.

## 2. Press the ▼ button to select [AF AUX. LIGHT] and press the ► button.

## 3. Press the ▲▼ buttons to select [ON] or [OFF].

## 4. Press the MENU/OK or ◀ button.

## 5. If the ◀ button was pressed in Step 4, press the MENU/OK button.

Now you have completed AF auxiliary light setting.

These settings are used until they are changed the next time.



### Note

The AF auxiliary lamp goes on when Auto-Focus does not function because of the dark surrounding area.

When you fully press the shutter button, the AF auxiliary lamp may not go on even if the surrounding area is dark.

# Setting Whether to Use Digital Zooming (DIGITAL ZOOM)

---

You can set whether to use digital zooming or not.

When ON (use of digital zooming) is selected, the  $Q/\square$  button works as a digital zoom button.

If this is set to OFF (not use), the exposure compensation or the white balance function can be assigned to the  $Q/\square$  button.

## 1. Display the setup menu.

For the operating procedure, see P.123.

## 2. Press the $\blacktriangledown$ button to select [DIGITAL ZOOM] and press the $\blacktriangleright$ button.

## 3. Press the $\blacktriangle\blacktriangledown$ buttons to select [ON] or [OFF].

## 4. Press the MENU/OK or $\blacktriangleleft$ button.

## 5. If the $\blacktriangleleft$ button was pressed in Step 4, press the MENU/OK button.

Now you have completed setting of digital zooming use or non-use. These settings are used until they are changed the next time.



## Reference

---

For details about using the Digital Zoom, see P.42.



# Changing the Zoom Button Setting (ZOOM BTN. SET.)

When you do not use digital zooming, you can assign the exposure compensation or white balancing function to the zoom button (Q/☒ button).

To change the zoom button setting, follow the steps below.

## 1. Display the setup menu.

For the operating procedure, see P.123.

## 2. Press the ▼ button to select [ZOOM BTN. SET.] and press the ► button.

## 3. Press the ▲▼ buttons to select [EXPO. CMP.] or [WHT. BAL.].

If you do not assign any function, select OFF.

## 4. Press the MENU/OK or ◀ button.

## 5. If the ◀ button was pressed in Step 4, press the MENU/OK button.

Now you have completed zoom button setting.

These settings are used until they are changed the next time.



# Registering the Power-on Settings (REG. MY SETTINGS)

---

The My Setting function allows you to make your desired settings to be used at power-on. For example, when a digital camera is used in common by multiple persons, each person can use the camera without regard to the settings made by the person who used the camera previously because the camera settings are restored to the administrator settings each time the camera is turned on.

Two types of my settings can be registered.

## Registering My Settings

To register the current camera settings as my settings, follow the steps below.

**1. Change the camera settings to the settings to be registered as my settings.**

**2. Display the SETUP menu.**

For the operating procedure, see P.123.

**3. Press the ▼ button to select [REG. MY SETTINGS] and press the ► button.**

A confirmation message appears.

**4. Select [SETTING 1] or [SETTING 2] and press the MENU/OK button.**

The current camera settings will be registered.

If you do not want to register them, press the DISP. button.

**5. Press the MENU/OK button.**

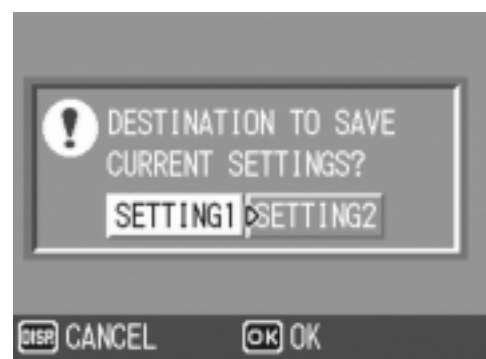

# Changing the Startup Settings (START SETTING)

To change the power-on setting using one of the current my settings, follow the steps below.

## 1. Display the setup menu.

For the operating procedure, see P.123.

## 2. Press the ▼ button to select [START SETTING] and press the ► button.

## 3. Select [SETTING 1] or [SETTING 2] and press the MENU/OK or ◀ button.

If you do not use the My Setting function, select OFF in step 3.

## 4. If the ◀ button was pressed in Step 3, press the MENU/OK button.

## 5. Turn your camera off.

The settings to be used at the next power-on will be changed.



### Note

- When [START SETTING] is set to OFF, settings are retained as usual. (P.190)
- When [START SETTING] is set to [SETTING 1] or [SETTING 2], the camera settings made with the My Setting function are used at power-on even if [RESTORE DEFAULTS] is selected.

### Settings Retained by My Setting Function

PIC QUALITY	EXPOSURE COMP.
FOCUS	WHITE BALANCE
Focal distance used in Manual Focus mode	ISO SETTING
PHOTOMETRY	FLASH
CONT. MODE	Scene Mode
IMG SET	Macro
IMAGE WITH SOUND	DENSITY
DATE IMPRINT	DISP. Mode



# Chapter 4

## Installing Software

<b>Installing the Provided Software (For Windows)..</b>	<b>152</b>
<b>Installing the Provided Software (For Macintosh) .....</b>	<b>171</b>



### Note

---

The Caplio Software contained on the supplied CD-ROM is used for Ricoh digital camera series, GR DIGITAL and Caplio, in common.

# Installing the Provided Software (For Windows)

You need to install software for transferring images to your computer before you can download images from the camera.

## Note

- If a file with the same name already exists at the destination, it is overwritten. If you do not want the file to be overwritten, rename the file or transfer images to another folder.
- When downloading images from the camera to your computer without necessary software installation, change [USB CONNECTION] to [MASS STR] on the camera (P.138).

## Reference

For how to download images from the camera into your computer, see the Software User Guide available from the Caplio Software CD-ROM. For how to display the Software User Guide, see P.155.

## Caution

- Be sure to install the software before you connect the camera to your computer. (P.157)
- When [MASS STR] is selected on the Setup menu of the camera, you can view the files in the camera without installing the supplied application or USB driver. At the time of purchase, [ORIGINAL] is selected.

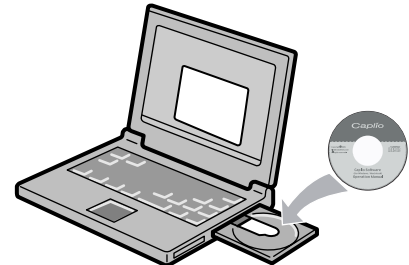

# Software that can be installed from the Caplio Software CD-ROM

Once you insert the Caplio Software CD-ROM in the CD-ROM drive, the following screen appears automatically:



Item Name	Description	Refer to
Installing the Software	Use this button to install software required for handling the camera and images.	P.157
Installing DeskTopBinder Lite		P.159
Browse User's Manual (Software Version)	Use this button to display the Software User Guide (PDF).	P.155
Browse CD-ROM Content	Use this button to display the list of files contained on the CD-ROM.	P.155
Go to Adobe Digital Imaging web site	Displays the home page of Adobe Systems Inc. (if connectable to Internet).	-

## When [Install the Software] is clicked: (P.157)

The following software will be installed:

Software	Windows		Description
	XP	98	
RICOH Gate La	<input type="radio"/>	<input type="radio"/>	Downloads images.
ImageMixer	<input type="radio"/>	<input type="radio"/>	Shot images can be displayed or edited and video CDs can be created. DirectX (see P.168) is necessary for handling movies.
USB Driver	<input type="radio"/>	<input type="radio"/>	Used to connect the camera to the computer. This driver is programmed for this camera. (It is also compatible with the existing models.)
WIA Driver	<input type="radio"/>	-	Used to capture images and connect the camera to the computer. This driver is programmed for this camera. (It is also compatible with the existing models.)

XP:Windows XP

98:Windows 98/98SE/Me/2000

## Reference

---

The camera is provided with software ImageMixer that allows you to display and edit images from your computer. For how to use ImageMixer, click the [?] button on the ImageMixer window and see the displayed manual.

For more information on the ImageMixer, contact the Customer Support Center below.

For the latest information about the ImageMixer, access the Web page of Pixela Co., Ltd. (<http://www.imagemixer.com>).

## Note

---

The WinASPI installer starts during installation of ImageMixer.

WinASPI is required when creating a Video CD using ImageMixer.

## When [Installing DeskTopBinder Lite] is clicked: (P.159)

The following software will be installed:

Software	Windows		Description
	XP	98	
DeskTopBinder Lite	<input type="radio"/>	<input type="radio"/>	Software used to manage business documents. Images in the camera can be downloaded to Ridoc using the Auto Document link that monitors document updating.
USB Driver	<input type="radio"/>	<input type="radio"/>	Used to connect the camera to the computer. This driver is programmed for this camera. (It is also compatible with the existing models.)
WIA Driver	<input type="radio"/>	-	Used to capture images and connect the camera to the computer. This driver is programmed for this camera. (It is also compatible with the existing models.)

XP:Windows XP

98:Windows 98/98SE/Me/2000

## Caution

---

The DeskTopBinder Lite is not in compliance with Windows 98 but with Windows 98 SE.

## Reference

---

- For details about the DeskTopBinder Lite, refer to the Read This First (PDF file), Setup Guide (PDF file), Ridoc Auto Document Link Guide (PDF file), and Help supplied with the DeskTopBinder Lite.
- For details about the Auto Document link, refer to the Ridoc Auto Document Link Guide (PDF file).



## When [Browse User's Manual (Software Version)] is clicked:

The Software User Guide (PDF file) on the Caplio Software CD-ROM can be displayed on your computer screen. If you are a Windows user and have Acrobat Reader installed on your computer, simply double-click [View Software User Guide].

If not installed, Acrobat Reader should be installed (see P.167).

## When [Browse CD-ROM] is clicked:

You can check folders and files on the CD-ROM.

The CD-ROM contains not only the Caplio software but also the following software. These software products run on Windows.

For the installation of each software product, see the Reference page in the table below.

Software	Description	Refer to
Acrobat Reader	Required for viewing the Software User Guide.	P.167
DirectX	Necessary for playing movies by the ImageMixer.	P.168

### Reference

---

- For details about the Acrobat Reader, see Help for the Acrobat Reader.
- To install ImageMixer alone, double-click Setup.exe in the ImageMixer folder.

# System Requirements for Using the Provided Software

---

The following environments are necessary for using the provided software. Please check your computer, or the computer's user manual.

Operating Systems Supported	Windows 98/98 Second Edition
	Windows 2000 Professional
	Windows Me
	Windows XP Home Edition/Professional
CPU	Pentium® III : 500MHz or more
Memory	Windows 98/98SE: 128MB or more
	Windows 2000: 128MB or more
	Windows Me: 128MB or more
	Windows XP: 256MB or more
Hard drive space required for installation	Windows 98/98SE: 500MB or more
	Windows 2000: 500MB or more
	Windows Me: 500MB or more
	Windows XP: 500MB or more
Display resolution	800 x 600 pixels or greater
Display colors	65000 colors or greater
CD-ROM drive	A CD-ROM drive compatible with the above-mentioned computer body
USB port	A USB port compatible with the above-mentioned computer body



## Caution

---

- If your computer has an upgraded OS, the USB function may not work normally, so it cannot be supported.
- Problems may arise due to changes made to the OS, such as through patches or a service package release.
- The camera does not support connection to a USB port added by using an extension function (PCI bus or other).
- If used in conjunction with a hub or other USB devices, the software may not work properly.
- When dealing with movies and other large files, a larger memory environment is recommended.



## Reference

---

For how to download images to your computer using an SD Memory Card, see the Software User Guide.

# Installing the Software on Your Computer



## Caution

- Do not connect your camera to the computer until indicated. If you happened to connect your camera to the computer (resulting in the [Add New Hardware Wizard] screen appearing), simply click [Cancel], and after disconnecting your camera, install the software on your computer.
- If a message is displayed during installation to uninstall the old Caplio software before installing the new one, uninstall the old Caplio software once and install the new one again by following the message instructions. Even with the new Caplio software, however, the image downloading and other functions of the old model can still be used as before. (For how to uninstall the software, see P.169.)
- For Windows XP or Windows 2000, Administrator privileges are required to install the software.



## Note

Here is an example of the Windows XP screen.

### 1. Start your computer and insert the Caplio CD-ROM in the CD-ROM drive.

The screen shown on the right appears automatically.



### 2. Click [Installing the Software].

After a while, the [Select Setting Language] screen appears.

### 3. Confirm the language, and then click [OK].

After a few moments, the [Welcome to InstallShield Wizard] screen appears.

### 4. Click [Next].

After a few moments, the [Select Installation Destination] screen appears.

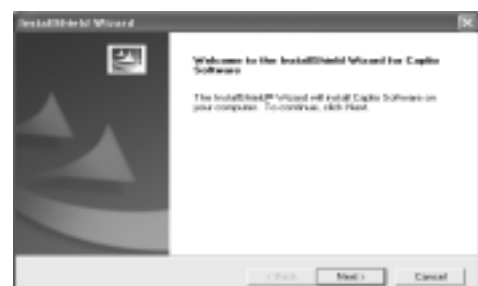

**5. Confirm where you want to install and then click [Next].**

The [Select Program Folder] screen appears.

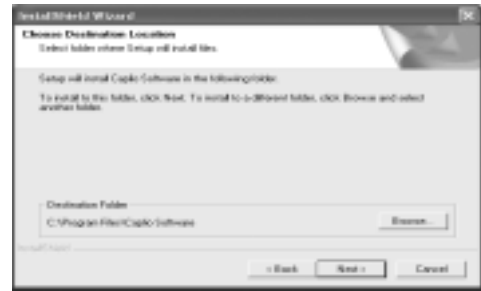

**6. Confirm where you want to install and then click [Next].**

The ImageMixer installer starts. Install ImageMixer following the messages displayed on the screen.

When installation of ImageMixer is completed, a dialog appears to indicate that all software applications have been installed.



**7. Click [Finish].**

**8. Restart your computer.**

 **Reference**

For how to remove (uninstall) the software, see P.169.

# Installing the DeskTopBinder Lite

## Reference

For how to use DeskTopBinder Lite, refer to the Beginner's Guide, the Setup Guide, and the DeskTopBinder Lite - Auto Document Link Guide (all PDF files) that are installed with DeskTopBinder Lite.

## Caution

- Do not connect your camera to the computer until indicated. If you happened to connect your camera to the computer (resulting in the [Add New Hardware Wizard] screen appearing), simply click [Cancel], and after disconnecting your camera, install the software on your computer.
- For Windows XP or Windows 2000, Administrator privileges are required to install the software.

## Note

Here is an example of the Windows XP screen.

### 1. **Start your computer and insert the Caplio CD-ROM in the CD-ROM drive.**

The screen shown on the right appears automatically.

### 2. **Click [Installing DeskTopBinder Lite].**

After a few moments, the [Welcome to InstallShield Wizard] screen appears.

### 3. **Click [Next].**

After a few moments, the [Select Installation Destination] screen appears.

### 4. **Confirm where you want to install and then click [Next].**

The [Select Program Folder] screen appears.

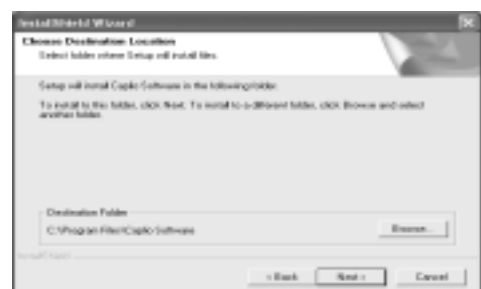

5. **Confirm where you want to install and then click [Next].**
6. **Click [OK].**
7. **Click [DeskTopBinder Lite].**

The DeskTopBinder Lite installer starts.

Install DeskTopBinder Lite following the messages displayed on the screen.

When the screen where you verify digital ID is displayed, click OK.

### **Caution**

---

- When capturing images from the camera using the Auto Document link of the DeskTopBinder Lite, deselect the [Automatically save on connection] check box in the [Optional Settings] dialog box displayed by selecting [Optional Settings] on the [RICOH Gate La Settings] menu. (Refer to the Software User Guide.) Before capturing images from the camera, set the date and time using the DATE SETTINGS option of the camera. (P.134)
- If you turned off and on the camera connected to the computer with the DeskTopBinder Lite in open state, reboot the computer with the camera connected.

# Connecting the Camera to Your Computer

## Downloading Images Using RICOH Gate La

After installing the software on your computer, connect your camera to the computer.

The following explanation is provided assuming that [ORIGINAL] (default) is selected at [USB CONNECTION] of the camera's Setup menu (P.138). If [MASS STR] is selected, change it to [ORIGINAL].

1. **Make sure the camera power is off.**
2. **Connect the USB cable to the USB port of your computer.**

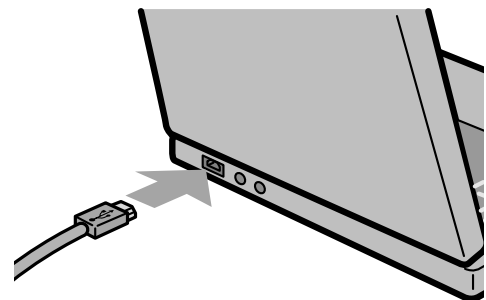

3. **Connect the USB cable to the USB terminal of your camera.**

Your camera turns on.

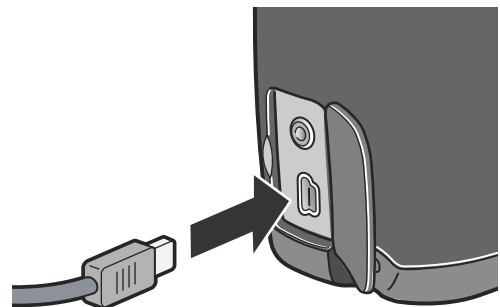

## For Windows XP

The first time you connect your camera to the computer using a USB cable, the [Found New Hardware Wizard] screen will appear.

1. **Select [Install the software automatically (Recommended)].**

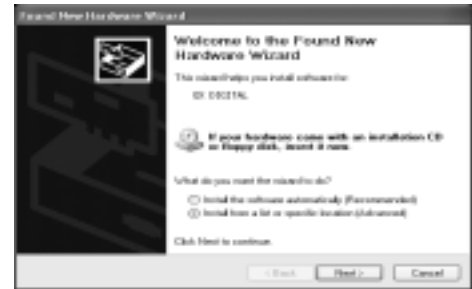

2. **Insert the Caplio Software CD-ROM into the CD-ROM drive on your computer.**

Installation of the WIA Driver automatically starts. If the CD-ROM is already on your computer when the [Found New Hardware Wizard] window is displayed, simply click [Next] to start installation.



### Reference

---

For how to turn the camera on/off, see P.29.



### Note

---

By default, the WIA driver is installed in the following location: (Specify the folder if the CD-ROM is not available.)

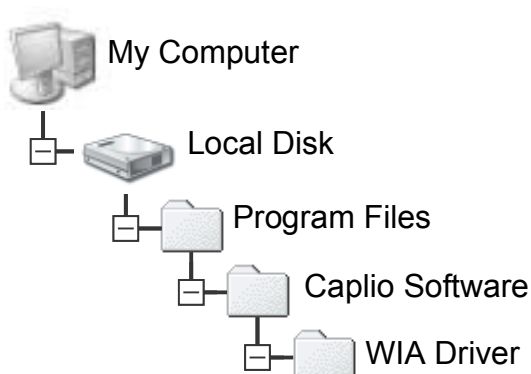



3. Select [RICOH Gate La], check [Always use this program for this action] check box, and then click [OK].

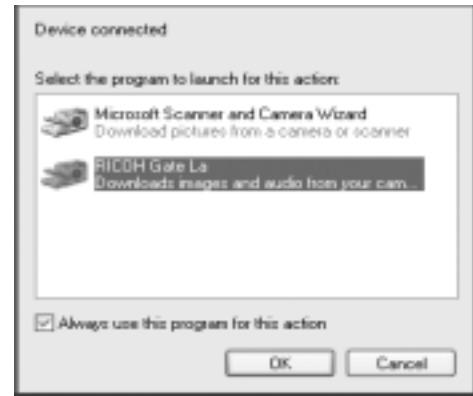

To load images from the camera with assistance from the Windows XP Scanner and Camera Wizard, select [Scanner and Camera Wizard]. Leaving the [Always use this program for this action] check box unchecked will cause the [GR DIGITAL] screen to be displayed each time you transfer images from the camera, thereby allowing you to choose whether to use RICOH Gate La or the Scanner and Camera Wizard for image transfers.

If your PC is installed with Windows XP Service Pack2 and a warning message is displayed, see P.185.

## Disconnecting the Camera from Your Computer:

1. Turn your camera off by pressing the power button.
2. Unplug the USB cable.

### Note

- If the computer does not recognize the camera, uninstall the software (P.169) and install it again.
- When downloading images from the camera, use of the AC adapter (sold separately) is recommended.

### Reference

- For how to turn the camera on/off, see P.29.
- For details about [USB CONNECTION](MASS STR/Original), see P.138.

# Transferring Images in Mass Storage Mode

## Caution

Windows 98/98 SE and Mac OS 8.6 are not compatible with Mass Storage Mode.

### 1. Change [USB CONNECTION] to [MASS STR] on the Setup menu.

For more details, see P.138. At the time of purchase, [Original] is selected.

### 2. Make sure that the camera power is off.

### 3. Connect the accessory USB cable to a USB port of your computer.

### 4. Connect the USB cable to the USB terminal of your camera.

Your camera turns on.

Your computer automatically reads a file necessary for recognizing the camera as a drive.

After this preparation, the camera is displayed as a drive at My Computer (Windows) or Desktop (Macintosh).



Example of the Windows XP

### 5. From the displayed drive, copy a file to the desired location.

The figure at right shows the folder configuration in the drive.

When the contents of the built-in memory are displayed, the drive name is RICOHDCI.

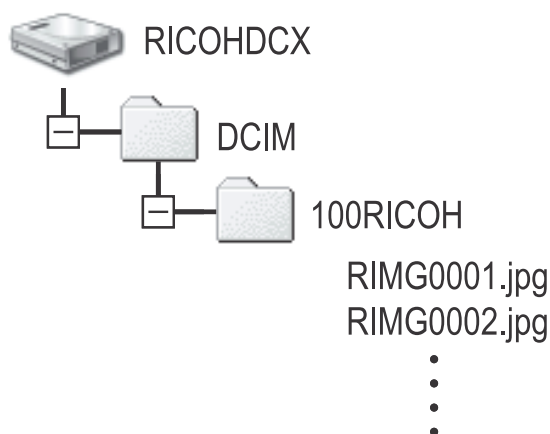

## Caution

During transfer, do not disconnect the USB cable.

## Note

When an SD memory card is inserted, its files are displayed. Otherwise, files in the built-in memory are displayed.

## Disconnecting the Camera from Your Computer (Windows)

The display is an example of Windows XP. The terms are different for other operating systems but the operations are the same.

- 1. Click the Remove Hardware Safely icon at the right end of the task bar.**
- 2. Select [USB Large-capacity Storage Device] and click [Stop].**
- 3. Check that [USB Large-capacity Storage Device] is selected and click [OK].**
- 4. Click [OK].**

## Disconnecting the Camera from Your Computer (Macintosh)

- 1. Put the displayed drive in the Recycle Bin.**

# Downloading Images from an SD Memory Card

---

It is possible to download images from an SD memory card to the computer via a PC card slot or card reader.

To load an SD memory Card into a PC card slot or card reader, use the PC card adapter.

## Images in an SD Memory Card

Images are stored in an SD Memory Card in a hierarchy shown below.

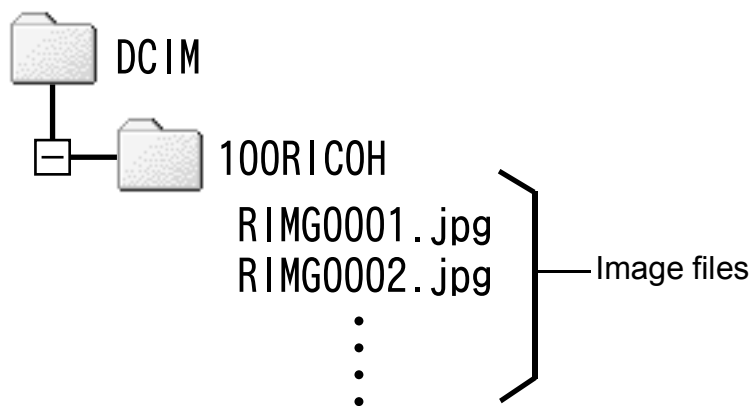

### Note

---

If the card reader is SD memory card compatible (directly loadable), no PC card adapter is required.



### Term

---

#### Card Reader

This is a device connected to a computer to read the contents of cards. In addition to the PC card type, there are card readers compatible with various types of cards, into which you can directly load a memory card.

# Installing Acrobat Reader

Acrobat Reader is required to display the operation manual (PDF file).

If the computer is running under Windows, Acrobat Reader can be installed.

Acrobat Reader need not be installed if already installed on your computer.

## Caution

- Do not install the software when the camera is connected to your computer with a USB cable.
- For Windows XP or Windows 2000, Administrator privileges are required to install the software.

### 1. Start your computer, and insert the included Caplio Software CD-ROM into the CD-ROM drive.

The following screen appears automatically.

### 2. Click [Browse CD-ROM].

The files on the CD-ROM are listed.

### 3. Double-click the [Acrobat] folder.

### 4. Double-click the [English] folder.

### 5. Double-click [ar500enu] (ar500enu.exe).

### 6. Install Acrobat Reader by following the messages displayed.



# Installing DirectX

---

DirectX is a program to play a movie file by the ImageMixer. This camera requires DirectX 8.1 or later to play movie files in Windows. If you have an earlier version installed, please install the updated version available on the accompanying CD-ROM. For Windows XP, installation of DirectX is not needed because the updated version is already installed.



## Caution

---

- Do not install the software when the camera is connected to your computer with a USB cable.
- For Windows XP or Windows 2000, Administrator privileges are required to install the software.

- 1. Start your computer, and insert the included Caplio Software CD-ROM into the CD-ROM drive.**
- 2. Click [Browse CD-ROM].**
- 3. Double-click the [DirectX] folder.**
- 4. Double-click the [English] folder.**
- 5. Double-click the following file:**

Windows98/98SE/Me	[DX81xxx.exe] in the [Win98Me] folder
Windows2000	[DX81NTxxx.exe] in the [Win2000] folder

# Uninstalling the Software

---



## Caution

---

- For Windows 2000/XP, Administrator privileges are required to uninstall the software.
- If any other program is active or unsaved data remains, save the data and terminate the program before uninstalling.
- If you install both the ImageMixer and the DeskTopBinder Lite and then uninstall either one, camera connection to the computer may fail. In this case, uninstall both [Caplio Software] and [Caplio Software S] and then install only the required one.

- 1. Click [Start] on the Windows task bar.**
- 2. Select [Settings]-[Control Panel] ([Control Panel] for XP).**
- 3. Double-click the [Add/Remove Programs] icon (or the [Add Or Remove Programs] icon in Windows XP).**
- 4. Select [Caplio Software] (select [Caplio Software S] if you have installed the DeskTopBinder Lite), and then click the [Add/Remove] button.**
- 5. Confirm file deletion and click [OK].**

The [Shared File Detected] dialog box appears.

- 6. Select the [Don't display this message again.] check box, and then click [OK].**

The uninstallation process begins. When it is finished, close the displayed window.

# Uninstalling the ImageMixer

---



## Caution

---

- For Windows 2000/XP, Administrator privileges are required to uninstall the software.
- If any other program is active or unsaved data remains, save the data and terminate the program before uninstalling.

- 1. Click [Start] on the Windows task bar.**
- 2. Select [Settings]-[Control Panel] ([Control Panel] for XP).**
- 3. Double-click the [Add/Remove Programs] icon (or the [Add Or Remove Programs] icon in Windows XP).**
- 4. Select [ImageMixer] and then click [Change/Remove].**
- 5. Confirm file deletion and click [OK].**
- 6. Select the [Don't display this message again.] check box, and then click [OK].**



# Installing the Provided Software (For Macintosh)

You need to install software for transferring images to your computer before you can download images from the camera.



## Reference

For how to download images from the camera into your computer, see the Software User Guide available from the Caplio Software CD-ROM. For how to display the Software User Guide, see P.172.



## Caution

Be sure to install the software before you connect the camera to your computer with the cable.

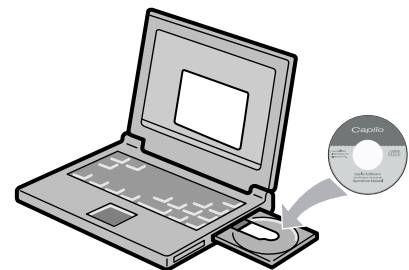

## Software that can be installed from the Caplio Software CD-ROM

Software	Mac		Description
	9	X	
RICOH Gate La	<input type="radio"/>	-	Downloads images.
USB Driver	<input type="radio"/>	<input type="radio"/>	Connects the camera to your computer.
Mounter	<input type="radio"/>	<input type="radio"/>	Connects the camera to your computer.

9: Mac OS 8.6 to Mac OS 9.2.2

X: Mac OS X 10.1.2 to 10.4

For Mac OS 8.6 to 9.2.2, double-clicking the [Caplio Installer] icon displays the screen on the right.



Item Name	Description
Installing the Software	Use this button to install software required for handling the camera and images.
Browse User's Manual (Software Version)	Use this button to display the Software User Guide (PDF).

### **When [Install the Software] is clicked:**

The following software will be installed.

### **When [Browse User's Manual (Software Version)] is clicked:**

The Software User Guide (PDF file) on the Caplio Software CD-ROM can be displayed on your computer screen.

If not installed, Acrobat Reader should be installed.

# System Requirements for Using the Provided Software

The following environments are necessary for using the provided software.

Please check your computer, or the computer's user manual.

Operating System	Mac OS 8.6 to 9.2.2 / Mac OS X 10.1.2 to 10.4	
Macintosh	A USB port standard-equipped Apple Macintosh Series	
Internal Memory	Mac OS 8.6 to 9.2.2	96 MB or more (128 MB or more recommended)
	Mac OS X 10.1.2 to 10.4	128 MB or more (256 MB or more recommended)
Application Allocated Memory (For Mac OS 8.6 to 9.2.2)	Without using the compression utility, 16MB or more (24 MB or more is recommended) as Application Memory	
Hard Disc Drive Capacity	Mac OS 8.6 to 9.2.2	10 MB or more (at installation)
	Mac OS X 10.1.2 to 10.4	100 MB or more (at installation)
	100 MB or more (at operation)	
Display resolution	640 x 480 pixels or greater (800 x 600 or greater recommended)	
Display colors	256 colors or greater (32000 or greater recommended)	
CD-ROM drive	A CD-ROM drive compatible with the above-mentioned Macintosh machine	
USB port	A USB port compatible with the above-mentioned computer body	

## Caution

- Problems may arise due to changes made to the OS environment setting.
- Connection to a USB port retrofitted using an extended function (PCI bus, etc.) cannot be supported.
- If used in conjunction with a hub or other USB devices, the software may not work properly.

## Note

- When dealing with movies and other large files, a larger memory environment is recommended.
- For Mac OS 8.6 to 9.2.2, use a larger memory environment, as well as allocating extra application memory.
- While the software can be operated at 256 colors or more for the Display Color, it is strongly recommended that 32,000 or more be used.

## Reference

For how to download images to your computer using an SD Memory Card, see the Software User Guide.

# Installing the Software on Your Computer (Mac OS 8.6 to 9.2.2)

---

1. Turn on your Macintosh and insert the Caplio Software CD-ROM in the CD-ROM drive.
2. Select the OS 9 folder.  
The [Installer] icon appears.
3. Double-click [Installer].  
The "Installer" window opens.



Installer

4. Click [Install the Software].
5. Click [OK].
6. Click [Install].  
When installation finishes, a message appears to inform you that it is necessary to restart your Macintosh.



7. Click [Continue].  
The software is installed and after a while the Installation Complete message appears.
8. Click [Restart].  
Your Macintosh restarts.



## Note

### To remove (uninstall) the software:

To remove (uninstall) the software from your Macintosh, drag and drop the installed file into the Trash.

File Name	Folder Name
RICOH Gate La	System Folder: Control Panels
RICOH Gate La Prefs	System Folder: Preferences
Caplio Mounter	System Folder: Extensions
Caplio Mounter Prefs	System Folder: Preferences
Caplio USB Driver	System Folder: Extensions
Caplio Lib	System Folder: Extensions

# Installing the Software on Your Computer (Mac OS X 10.1.2 to 10.4)

1. Turn on your Macintosh and insert the Caplio CD-ROM in the CD-ROM drive.

2. Open the Mac OS X folder.

The [Caplio Mounter.pkg] icon appears.

3. Double-click [Caplio Mounter.pkg].

The Installer starts. A screen appears prompting you to enter the administrator's password.



Caplio Mounter

4. Click the key icon.

An authentication window appears.



5. Enter the administrator's name and password, and then click [OK].



6. Click [Continue].

The [Select a Destination] screen appears.



**7. Click the destination volume you want, and then click [Continue].**



**8. Click [Install].**

When installation finishes, a message appears to inform you that it is necessary to restart your Macintosh.

**9. Click [Continue Installation].**

The software is installed, and after a while an Installation Complete message appears.



**10. Click [Restart].**

Your Macintosh restarts.



## Note

**To remove (uninstall) the software:**

1. Start [Caplio Mounter] in [Applications] folder.
2. Select [Uninstall] in [File] menu.

The uninstallation process begins.

# Installing Adobe® Photoshop® Elements (Trial Version)

---

The supplied Adobe® Photoshop® Elements (Trial Version) is digital image editing software. With this software, you can read and process the files shot in the RAW mode (P.69).

To install Adobe® Photoshop® Elements (Trial Version), follow the steps below.

Operating system supported	Windows 2000 Professional, Service Pack 4 and later
	Windows XP Home Edition/Professional, Service Pack 1 and later
	Mac OS X 10.2.8
	Mac OS X 10.3

## For Windows

- 1. Turn on the computer and insert the supplied Adobe® Photoshop® Elements (Trial Version) CD-ROM into the CD-ROM driver.**
- 2. Open [My Computer] and double-click the CD-ROM drive icon.**
- 3. Double-click "Setup.exe".**
- 4. Install Adobe® Photoshop® Elements (Trial Version) following the messages displayed on the LCD monitor.**

## For Macintosh

- 1. Turn on the computer and insert the supplied Adobe® Photoshop® Elements (Trial Version) CD-ROM into the CD-ROM driver.**
- 2. Double-click the CD-ROM drive icon.**
- 3. Double-click "pse3\_mac\_ue.dmg".**  
An Adobe® Photoshop® Elements (Trial Version) volume is created.
- 4. Double-click "Adobe Photoshop Elements.pkg".**
- 5. Install Adobe® Photoshop® Elements (Trial Version) following the messages displayed on the LCD monitor.**



### Reference

---

- For how to use Adobe® Photoshop® Elements, see the online help for Adobe® Photoshop® Elements.
- For detailed information about Adobe® Photoshop® and DNG format, access the home page (<http://www.adobe.com/digitalimag/main.html>) of Adobe Systems Inc.
- The trial version is offered only for your evaluation. You can use all functions free of charge for 30 days starting from the date of first activation.
- Note that no support is provided for the trial version user.



# Chapter 5

## Troubleshooting

Troubleshooting .....	180
Appendices .....	187



### Caution

---

Never use any battery other than the specified one.



### Reference

---

For the applicable battery, see P.19.

# Troubleshooting



## Troubleshooting the Camera

### Power Supply

Symptom	Cause	Remedy	Refer to
The power does not come on.	Batteries are not loaded. Or they are exhausted.	Load the rechargeable battery correctly. Recharge the battery as required. Use the AC adapter as required.	P.25 P.26
	The battery is unacceptable.	Replace the batteries with acceptable ones.	P.19
	The AC Adapter is not connected correctly.	Reconnect it properly.	P.26
	The camera is automatically turned off by Auto Power-off.	Turn on the camera again.	P.29
	The battery is loaded in wrong orientation.	Load the battery in correct orientation.	P.28
The power cuts out during use.	The camera was left unattended and unused, so Auto Power-Off shut it off.	Turn on the camera again.	P.29
	Batteries are running low.	When alkaline batteries are in use, replace them with new ones. When a rechargeable battery is used, recharge it or use an AC adapter.	P.25 P.26 P.28
	An unacceptable battery (manganese dry cell or other) is used.	Replace the battery with an acceptable one.	P.19
The power does not go off.	Camera malfunction.	Remove batteries once and load them again. Reconnect the AC adapter cable properly, if using.	P.26 P.28
The low-battery mark is displayed although the batteries are new. The lens is retracted when the shutter button is pressed. The camera is turned off although the batteries are new.	The batteries are unacceptable.	Replace the batteries with acceptable ones.	P.20
Cannot recharge the batteries.	Battery life.	Replace the batteries with a new set.	P.28
Batteries run out quickly.	They are being used in extreme high or low temperatures.	-	-
	Many shots are being taken in dark places inside, requiring flash.	-	-

# Shooting

Symptom	Cause	Remedy	Refer to
The camera does not shoot even if you press the shutter release button.	Batteries are not loaded. Or they are exhausted.	If using alkaline batteries, replace the batteries with a new set. If using rechargeable batteries, recharge or use the AC Adapter.	P.25 P.26 P.28
	The power is not turned on or the camera is not in the shooting mode.	Turn on the camera and turn the Mode Dial to the shooting mode.	P.29
	The shutter button is not pressed all the way.	Press the shutter button all the way.	P.36 P.37
	The Memory Card is not formatted.	Format the card.	P.124
	The Memory Card does not have any free space.	Load a new card, or delete unwanted files.	P.25 P.56
	End of Memory Card life.	Load a new memory card.	P.25
	The flash is recharging.	Wait until the flash lamp stops blinking.	P.44
	The SD Memory Card is "locked".	Release the "Lock (write-protection)".	P.22
	The SD Memory Card's contact surfaces are dirty.	Wipe off with a soft, dry cloth.	-
Failed to confirm the shot image.	The image confirmation time is too short.	Lengthen the image confirmation time.	P.131
Images do not appear on the LCD Monitor.	The power is not on. Or the LCD Monitor is dark.	Turn the power on. Or adjust the brightness of the LCD Monitor.	P.29 P.126
	The VIDEO/AV cable is connected.	Disconnect the VIDEO/AV cable.	P.54
	The screen display status is in [SYNCHRO-MONITOR MODE].	Press the DISP. button and switch display.	P.32
Although it is set to Auto Focus, it does not focus.	The lens or AF Window is dirty.	Wipe clean with a soft, dry cloth.	P.14
	The subject is not in the center of the shooting range.	Shoot with Focus Lock.	P.40
	It is a hard-to-focus subject.	Shoot with Focus Lock or Manual Focus.	P.40 P.74
A picture is blurred.	You moved the camera when pressing the shutter release button.	Hold the camera with your elbows tight on your body. Or use a tripod.	P.34
	When shooting in a dark place (ex. indoor), the shutter speed slows down and pictures become easily blurred.	Use the flash. Or, raise the ISO sensitivity.	P.44 P.91

Symptom	Cause	Remedy	Refer to
The flash does not fire. Or the flash cannot recharge.	Flashing is prohibited in the following statuses: - White Balance Bracket enabled - Continuous Shooting Mode - Movie Mode	For shooting with the flash, change the settings or mode.	P.81 P.101 P.105
	The flash is set to Flash Off.	Deselect the Flash Off with the  button.	P.44
	Batteries are running low.	If using alkaline batteries, replace the batteries with a new set. If using rechargeable batteries, recharge or use the AC Adapter.	P.19
	Your hand is on the popup or strobe section of the flash.	Keep your hand away.	P.14
	The popup section of the flash is not completely open.	Take corrective measures against the popup failure (such as adjusting the external flash).	P.45
Even though the flash fired, the picture is dark.	The distance to the subject is greater than 2.9 meters.	Get closer to your subject and shoot.	P.44
	The subject is dark.	Correct exposure. (Exposure correction also changes the light quantity of the flash.)	P.87
The image is too bright.	The light quantity of the flash is not appropriate.	Move a little away from the subject or light up the subject for shooting without flashing.	P.44
	It is over-exposed.	Use exposure compensation. Cancel Time Exposure.	P.87
	The brightness of the LCD monitor is not appropriate.	Adjust the brightness of the LCD Monitor.	P.126
The image is too dark.	The shot was taken in a dark place while set to  (Flash Off).	Deselect the Flash Off with the  button.	P.44
	It is under-exposed.	Use exposure compensation. Set to Time Exposure.	P.87
	The brightness of the LCD monitor is not appropriate.	Adjust the brightness of the LCD Monitor.	P.126
The image lacks natural color.	The picture was shot in conditions that are hard for Auto White Balance to adjust to.	Add a white object to the composition. Or use a White Balance setting other than Auto.	P.88
The date, or recording information does not appear.	The screen display function is set to No Display.	Press the DISP. button and switch display.	P.32
The brightness of the LCD Monitor changes during AF.	You are using it in a dark place or when Auto Focus range and surrounding brightness are different.	This is normal.	-
There is a vertical smear on the image.	This is a phenomenon that occurs when a bright subject is shot. It is called the smear phenomenon.	This is normal.	-

# Playback/Deleting

Symptom	Cause	Remedy	Refer to
Cannot Playback. Or the Playback screen does not come out.	The camera is not in Playback Mode.	Press the  (Playback) button.	P.48
	The VIDEO/AV cable is not connected properly.	Reconnect it properly.	P.54
	The video format is set wrong.	Set to correct format.	P.136
The contents of SD Memory Card cannot be replayed. Or the Playback screen does not come out.	No memory card is loaded. Or a Memory Card with no stored images is loaded.	Load a card with stored images.	P.25
	You played back a Memory Card that was not formatted by this device.	Load a card that was formatted and stored on by this device.	P.25 P.124
	You played back a Memory Card that was not recorded normally.	Load a normally recorded card.	-
	The SD Memory Card's contact surfaces are dirty.	Wipe off with a soft, dry cloth.	-
	There is something wrong with the Memory Card.	Play another card and if there is nothing wrong with it, the camera is OK. There may be something wrong with the card, so do not use it.	-
An image disappeared.	Batteries are running low.	If using alkaline batteries, replace the batteries with a new set. If using rechargeable batteries, recharge or use the AC Adapter.	P.19
	The camera was left unattended and unused, so Auto Power-Off shut it off.	Turn the power back on.	P.29
Files cannot be deleted.	The file has been set to protect.	Release the protection.	P.112
	The SD Memory Card is "locked".	Release the "Lock (write-protection)".	P.22
Cannot format a Memory Card.	The SD Memory Card is "locked".	Release the "Lock (write-protection)".	P.22

## About the Software

For details about the software, refer to the Software User Guide (PDF file).

## Other Problems

Symptom	Cause	Remedy	Refer to
Cannot load the Memory Card.	The card is facing the wrong way.	Load correctly.	P.25
Even when the camera's buttons are pressed, it does not operate.	Batteries are running low.	If using alkaline batteries, replace the batteries with a new set. If using rechargeable batteries, recharge or use the AC Adapter.	P.19 P.25 P.26
	Camera malfunction.	Press the Power button to turn the power off, and then press the Power button to turn the power on again.	P.29
		Remove batteries once and load them again. Reconnect the AC adapter cable properly, if using.	P.19 P.25 P.26
The date is wrong.	The correct date/time are not set.	Set the correct date/time.	P.134
The date set has disappeared.	The batteries were removed.	If the batteries are removed for about one week, the date setting will be lost. Make the settings again.	P.134
Auto Power-Off does not work.	Auto Power-Off is set to OFF.	Set the time for Auto Power-Off.	P.128
The beep does not sound.	The camera is set to silent.	Mute is set at [Volume Setting].	P.130
Images do not appear on the TV.	The video format is set wrong.	Set to correct format.	P.136
	The cable is not connected.	Reconnect the cable properly.	P.54
	The TV in/out switch is incorrectly set.	Check that the TV in/out switch is set correctly.	-

# Warning Messages Under Windows XP Service Pack 2

---

When software for Ricoh's digital camera is used on a PC with Windows XP Service Pack 2 installed, the following warning message may appear at software activation or USB connection.

With this in mind, refer to the following:

1. Check the information provided on the message screen to make sure that it comes from a reputable source, and then click the [Unblock] button.

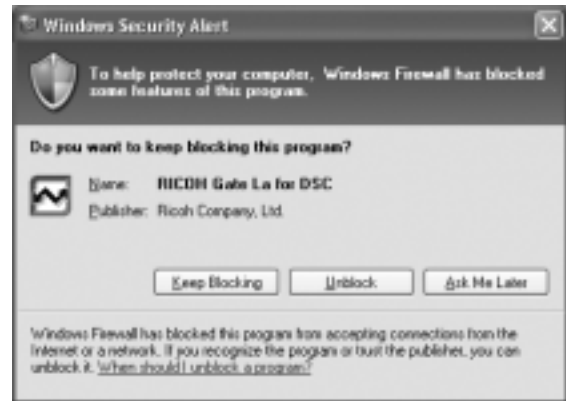

## Caution

If you do not recognize the program, you should block it because it may be a virus. Click the [Keep Blocking] button to prevent the program from connecting to the Internet.

## If you clicked the [Keep Blocking] button:

Follow the steps below to check to see the Windows Firewall settings.

1. Click [Start] and then [Control Panel].
2. Double-click [Windows Firewall].

If [Windows Firewall] is not displayed, click [Switch to Classic Display] at the upper left of the window.



Windows  
Firewall

3. Click the [Exceptions] tab.
4. Check that the software is in [Programs and Services].
5. Click the [Add Program] button to add software that uses the network.



## If you clicked the [Ask Me Later] button:

Each time the program is activated, the [Critical Warning about Windows Security] window appears. Then you can select [Unblock].



# Appendices

## A. Specifications

---

### General

Video Signal Format	NTSC, PAL
Power Source Voltage	AAA Dry Alkaline Batteries (1.5 V) X 2 Rechargeable Battery (3.7 V) X 1 External Part (AC Adapter); 3.8 V
External Dimensions	107.0 mm (W) x 58.0 mm (H) x25.0 mm (D) (excluding projecting parts)
Weight	Camera: Approximately 170 g (Excluding the battery, SD memory card, and strap)
Tripod hole shape	1/4-20UNC
Operating Temperature Range	0 °C to 40 °C
Operating Humidity Range	85% or less
Storage Temperature Range	-20 °C to 60 °C

### Camera Parts

Image Pickup Used	Total 8.30 million pixels (effective pixels 8.13 million) 1/1.8" primary color CCD
Lens	
• Lens	F2.4
• Focal Length	F: 5.9 mm (35 mm equivalent, 28 mm)
• Shooting distance	Approximately 0.3 m to $\infty$ from the front of the lens
• Macro shooting distance	Approximately 0.015 m to $\infty$ from the front of the lens
• Digital Zoom	4.0 times
Monitor Display Parts	
• Screen Size	2.5"
• Type	Cold polysilicone TFT LCD
• Pixel Count	Approx. 210,000
• White Balance	AUTO/Fixed (Daylight, Overcast, Tungsten light, Fluorescent light, Manual Setting, Detail)
Exposure Adjustment	
• Light Metering Sensitivity Distribution	Multi Light Metering (256 segments), Center-weighted Light Metering, Spot Metering
• Exposure Compensation	Exposure Compensation +/-2.0EV (1/3EV Steps)
• Metering Method	TTL-CCD Metering Method
• Flash AE	Yes (In Daylight Synchro: On)
• Shutter	Still image: 180, 120, 60, 30, 15, 8, 4, 2, 1 to 1/2000 seconds Movie: 1/30 to 1/2000 seconds

- ISO Sensitivity AUTO, ISO64, ISO100, ISO200, ISO400, ISO800, ISO1600
  - Aperture F-value : F2.4, F3.5, F7.1, F10, F11 (F7.1 to F11 with ND filter)  
P, A, M: F2.4, F2.8, F3.2, F3.5, F4.0, F4.5, F5.0, F5.6, F6.3, F7.1, F8.0, F9.0
- Distance Control
- AF Method Normal Shooting: External Passive / CCD method; Macro: CCD method
  - AF Measurement Range Normal: approx. 0.3 m - infinity. Macro: approx. 0.015 m - infinity
- Internal Flash
- Method Flashmatic
  - Shooting Distance Approx. 0.2 to 3.0 m (ISO:AUTO)
  - Operating Modes Flash Off/Forced flash/Auto/Slow synchro/Red-eye reduction
  - Date Maintain Time Approx. 1 week

## Image Data Record/Replay Part

### Pixels

- Still Images 3264 X 2448, 3264 X 2176, 2592 X 1944, 2048 X 1536, 1280 X 960, 640 X 480
- Text 3264 X 2448, 2048 X 1536
- Movies 320 X 240, 160 X 120

### File Formats

- Still Images JPEG (Exif Ver.2.21), RAW (DNG)
- Text TIFF (MMR Method ITU-T.6)
- Movies AVI (Open DML Motion JPEG Format Compliant)
- Sounds WAV (Exif Ver.2.21  $\mu$  law)

Camera File System Standard DCF (DCF is an abbreviation for "Design rule for Camera File system", a JEITA standard)

Compression Format JPEG Baseline Format Compliant (Still, Movie)

### Image Size

- 3264 X 2448 N; approx. 1665 KB/Screen, F; approx. 2894 KB/ Screen, RAW; approx. 11.52 MB/ Screen
- 3264 X 2176 F; approx. 2576 KB/Screen, RAW; approx. 10.25 MB/ Screen
- 2592 X 1944 N; approx. 1063 KB/Screen
- 2048 X 1536 N; approx. 672 KB/Screen
- 1280 X 960 N; approx. 356KB/Screen
- 640 X 480 N; approx. 83KB/ Screen

## I/O Terminals

DC In 3.8 V (AC Adapter)

Video Out 1.0 Vp-p (75 $\Omega$ )

## Memory Cards that can Record, Playback

Memory Type SD Memory Card, Multi-Media Card

## B. Recommended Parts

---

Recommended external flashes are as follows:

Distributor	Product name	Model name
Sigma	EF-500 DG SUPER	SA-STTL
Sigma	EF-500 DG ST	SA-STTL

When using a recommended flash, follow the steps below.

- 1. Select FLASH OFF as the flash mode of the built-in flash. (P.44)**
- 2. Turn off the camera and flash.**
- 3. Attach the external flash to the hot shoe on the camera.**
- 4. Turn on the external flash.**
- 5. Turn on the camera.**
- 6. Make sure that the external flash icon is displayed on the LCD monitor.**



### Caution

---

If the internal flash is set to other than [Flash Off], the internal flash cover may be lifted even when an external flash is attached.

### Note





---

- When the external flash icon is displayed on the LCD monitor, the built-in flash does not go on.
- If the camera does not recognize the external flash, turn off the external flash and camera, detach the external flash, and attach it again.

## C. Menu Items By Mode

\*Among the choices listed in the table below, default values at purchase are enclosed in [ ].

### Shooting Menu (Movie Mode)

Setting	Option	Refer to
MOVIE SIZE	[320], 160	P.69
FOCUS	[MULTI AF], SPOT AF, MF, SNAP, ∞	P.74
WHITE BALANCE	[AUTO],  (Daylight),  (Overcast),  (Tungsten light),  (Fluorescent light), [M] (Manual Setting), [CT] (Detail)	P.88

### Shooting Menu (Text Mode)

Setting	Option	Refer to
DENSITY	DEEP, [NORMAL], LIGHT	P.93
SIZE	3264, [2048]	P.69
IMAGE WITH SOUND	ON, [OFF]	P.85
DATE IMPRINT	[OFF], DATE, TIME	P.86

## D. Functions Whose Defaults will be Restored upon Power-off

Power-off may reset some function settings to their defaults. The table below indicates whether or not the function will be reset to its defaults upon power-off.

Mode	Function	The current setting is kept:O, Restored:X
Setup	LCD BRIGHTNESS	○
	ADJ. BTN. SET. 1 ADJ. BTN. SET. 2	○
	AUTO POWER OFF	○
	BEEP SOUND	○
	VOL. SETTINGS	○
	LCD CONFIRM.	○
	SEQUENTIAL NO.	○
	DATE SETTING	○
	LANGUAGE	○
	VIDEO OUT MODE	○
	SHTG STGS WARNG.	○

Mode	Function	The current setting is kept:O, Restored:X
	USB CONNECTION	○
	ENLGE PHOTO ICON	○
	COLOR SPACE SET	○
	DIGITAL ZOOM	○
	AF AUX. LIGHT	○
Shooting	PIC QUALITY/SIZE	○
	MOVIE SIZE (Movie Mode)	○
	SIZE (Text Mode)	○
	DENSITY (Text Mode)	○
	FOCUS	○
	PHOTOMETRY	○
	CONT. MODE	X
	IMG SET	○
	AUTO BRACKET	X
	INTERVAL	X
	IMAGE WITH SOUND	X
	DATE IMPRINT	○
	EXPOSURE COMP.	○
	WHITE BALANCE	○
	ISO SETTING	○
	SELF-TIMER	X
	FLASH	○
	MACRO SHOOTING	X
	LCD DISPLAY	○
	SCENE MODE	○
	ADJ. MODE	○
Playback	LCD DISPLAY	○
	VOLUME	○

## E. Number of Images That Can be Stored in Internal Memory/SD Memory Card

The following table shows the approximate number of images that can be recorded onto an SD memory card at various image size and picture quality settings.

Mode	Picture Quality	Image Size	IN	32MB	64MB	128MB	256MB	512MB	1GB
Still Image	RAW	3264 X 2448	1	2	4	8	16	33	64
	RAW	3264 X 2176	1	2	4	9	18	37	72
	F	3264 X 2448	8	9	19	39	78	158	305
	F	3264 X 2176	9	10	21	44	88	177	341
	N	3264 X 2448	14	16	33	68	136	275	530
	N	2592 X 1944	22	25	53	107	213	430	828
	N	2048 X 1536	36	41	84	170	339	683	1314
	N	1280 X 960	63	72	148	301	600	1209	2324
	N	640 X 480	277	315	645	1304	2599	5237	10072
TEXT MODE	3264 X 2448		67	75	154	313	624	1257	2417
	2048 X 1536		88	99	203	412	821	1654	3181
Movie	320 X 240		39 s	44 s	1 min 31 s	3 min 4 s	6 min 7 s	12 min 19 s	23 min 42 s
	160 X 120		2 min 26 s	2 min 46 s	5 min 40 s	11 min 27 s	22 min 50 s	46 min 1 s	88 min 431 s
Sound (Voice Memo)			56 min 45 s	64 min 36 s	132 min 11 s	267 min 15 s	532 min 36 s	1073 min 00 s	2063 min 25 s

### Note

- The number of remaining shots displayed on the LCD monitor may differ from the actual number of shots, depending on the subject.
- The maximum number of pictures and other numeric values may be different even for cards of the same capacity if the manufacturer, type, or shooting conditions are different.
- The continuous shooting (recording) time depends on the card type, capacity, and performance.

## F. Operations that can be Performed with the Up-down Dial and ADJ. Dial

Tuning the up-down dial and ADJ. dial and pressing the ADJ. dial just like a pushbutton allows you to perform various camera operations.

Operations that can be performed with the up-down dial and ADJ. dial are listed below.

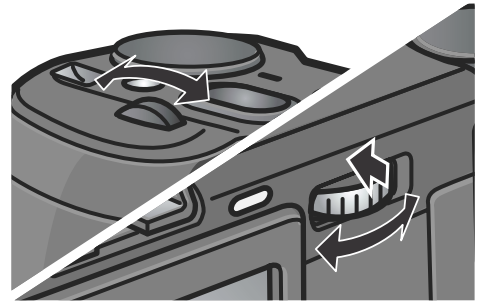

Mode/Screen	Refer to	Function	
		Up-down dial	ADJ. dial
Playback mode (Normal playback screen)	P.49	Same as ◀▶ buttons.	Same as ◀▶ buttons.
Playback mode (Enlarged playback screen)	P.53	Change the magnification of enlarged display screen.	Switched to the previous/next image. * When the image is switched to the previous/next image on the enlarged playback screen, the previous/next image is displayed at the normal enlargement ratio (100%).
Playback mode (three-frame view screen)	P.50	Same as ◀▶ buttons.	Same as ◀▶ buttons.
Playback mode (thumbnail view screen)	P.52	Same as ▲▼ buttons.	Same as ◀▶ buttons.
SCENE mode (SCENE selection screen)	P.47	Same as ▲▼ buttons.	-
Shooting/Playback/ Setup menu	P.67 P.110 P.122	Same as ▲▼ buttons.	Same as ◀▶ buttons.
Transition to ADJ. mode	P.65	-	When pressed: Transits to the ADJ. mode.
ADJ. mode	P.65	Same as ▲▼ buttons	Same as ◀▶ buttons
Aperture Priority mode	P.96	Changes the aperture (F-value).	-
Manual exposure mode	P.97	Changes the aperture (F-value).	Changes the shutter speed.
Program Shift mode	P.99	Changes the combination of aperture (F-value) and shutter speed.	-

## G. Using Your Camera Abroad

---

### AC Adapter (Model AC-4c)

Can be used in regions with a current of 120V, 50Hz/60Hz.

If you are going to travel to a country that uses a different shaped wall outlet/plug, please consult your travel agent on a plug adapter suitable for wall outlets in your country of destination.

### Warranty

This product is for domestic use. The warranty is only valid domestically.

Should the product fail or malfunction while you are abroad, the manufacturer assumes no responsibility for servicing the product locally or bearing the expenditure incurred therefore.

### Using Playback on Television in other Regions

Playback is possible on televisions (or monitors) equipped with a video input terminal. Please use the video cable provided.

This camera is compatible with both NTSC and PAL television formats. Switch the video format on the camera to match the television environment in the region.

When you go overseas, set your camera to the local video format.



## H. Cautions on Use

---

- This product is for domestic use. The warranty is only valid domestically.
- Should the product fail or malfunction while you are abroad, the manufacturer assumes no responsibility for servicing the product locally or bearing the expenditure incurred therefore.
- Be sure not to drop or apply any sudden force to the camera.
- Firing the flash consecutively may heat the firing unit. Do not fire it consecutively more than necessary.
- Do not fire the flash near eyes. It could cause visual impairment (particularly for infants).
- Do not fire the flash near the driver of a vehicle to avoid causing accidents.
- The batteries may become hot after extended use. Touching the batteries immediately after use could result in burns to your fingers.
- If the LCD monitor or panel is exposed to sunlight, they may become washed out and images may become hard to view.
- The LCD monitor and panel may contain some pixels that do not remain lit up continually in part or at all. Also, the brightness may become uneven because of the characteristics of LCDs. These are not failures.
- While you are carrying the camera, be careful not to hit it against other objects.
- In an environment where the temperature changes suddenly, condensation may occur in the camera, resulting in troubles such as fogging of the glass surface or malfunctions of the camera. If this occurs, place the camera in a bag to slow the temperature change as much as possible. Take it out of the bag after the temperature difference from the atmosphere has decreased to a fairly small amount.
- To avoid damaging the connectors, do not put any objects into the camera's microphone or speaker holes.



### Note

---

#### **Conditions in which condensation may easily occur:**

- When the camera is moved to an environment where the temperature differs greatly.
- In humid places
- In a room immediately after being heated, or when the camera is exposed directly to cooled air from an air-conditioner or another similar appliance

# I. Care and Storage

---

## Care

- Please note that if fingerprints, dirt, etc. get onto the lens, picture quality will suffer.
- When dust or dirt does get on the lens, do not touch it directly with your fingers, and either use a blower (available in stores) to blow it off, or a soft cloth to gently dust it off.
- After use at the beach or around chemicals, wipe it off particularly carefully.
- In the unlikely event that your camera fails to work properly, please consult your Ricoh Repair Center.
- There are high voltage circuits in this camera. As this is dangerous, do not dismantle this camera under any circumstances.
- Do not get volatile substances, such as thinner, benzene, or pesticides on your camera. This may cause a change in quality, paint to peel, etc.
- As the surface of the LCD Monitor is easily scratched, do not rub hard objects against it.
- Please clean the surface of the LCD Monitor with solvents available on the market specially for cleaning LCD display surfaces. Gently wipe with a soft cloth dampened with a little cleaner.

## Storage

- Please avoid storing your camera in the following kinds of places, as breakdown may result.
  - In high heat and humidity, or where there is severe change in temperature or humidity.
  - Places with a lot of dust, dirt or sand.
  - Places with severe vibration.
  - In places of direct contact with vinyl products, rubber or chemicals, such as insect repellent, etc.
  - Places with strong magnetic fields (monitors, next to strong magnets, etc.).
- If you are using a battery or batteries, remove them if you are not going to use the camera for a long period of time.

## Precautions regarding care of your camera

1. Be sure to turn the power off.
2. Remove the batteries or AC Adapter before caring for your camera.

## J. Error Messages

If an error message is displayed on the LCD Monitor, take the corresponding action.

Error Message	Cause and Action	Page
INSERT CARD	No card is loaded. Insert a card.	P.25
SET THE DATE ON THE SETUP MENU	The date is not set. Set the date.	P.134
FILE NUMBER OVER	The file number limit has been exceeded. Please use another card, or delete unwanted files.	P.132
UNMATCHED FILE	The camera cannot display this file. Check the file contents on your computer, and then delete the file.	-
INSUFFICIENT MEMORY. CONTINUE?	Because there is not sufficient capacity on the card, all the files cannot be copied. Use another card.	P.22
PROTECTED	You are trying to delete a protected file.	P.112
THE CARD IS WRITE-PROTECTED.	The card is "Locked (write-protection)". Unlock the card.	P.22
PRINT SETTINGS CANNOT BE SET FOR THIS FILE	This file (movies and other) cannot be selected for printing.	-
INSUFFICIENT MEMORY	Files cannot be stored. Make sure there is enough free space, or delete files.	P.56, P.124, P.125
	The image print number limit has been exceeded. Select an image and set the number to 0.	-
FORMAT INTERNAL MEMORY	It is necessary to format internal memory.	P.125
FORMAT CARD	The card is not formatted.Format the card.	P.124
CARD ERROR	Please reformat. If, after doing so, the error message still appears, the card may be faulty. Do not use the card.	P.124
WRITE TO CARD	Writing file to memory. Wait until writing finishes.	-
NO FILE	There are no files that can be played back.	-
CANNOT RECORD	The Number of remaining shots is 0. Switch to another card or internal memory.	-

## K. Warranty and Servicing

---

1. This product is backed by a limited warranty. During the warranty period mentioned in the Warranty supplied with your camera, any defective parts will be repaired free of charge. In the event of a camera malfunction, contact the dealer from which you purchased the camera or your nearest Ricoh service office. Please note that you will be not be reimbursed for the cost of bringing the camera to the Ricoh service office.
2. This warranty does not cover any damage resulting from:
  - 1) failure to follow the instructions in the instruction manual;
  - 2) repair, modification or overhaul not conducted by an authorized service center listed in the instruction manual;
  - 3) fire or natural disaster;
  - 4) Improper storage, such as exposing the camera to high temperatures, humidity, or moth-balls; storing it with a leaking battery; storing the camera in a dirty condition so that it becomes moldy; or otherwise insufficiently caring for the camera;
  - 5) Submergence; exposure to floods or spilled alcohol or other beverages; allowing sand or mud to enter the camera; exposure to physical shocks; or dropping the camera.
3. After the warranty period has passed, you will be liable for all repair fees, including those incurred at an authorized service center.
4. You will be liable for all repair fees, even within the warranty period, if the warranty card is not attached or if the distributor's name or the purchase date have been changed or are not indicated on the card.
5. Expenses for overhaul and thorough inspection by special request of the customer will be charged to the customer, whether or not they are incurred during the warranty period.
6. This warranty only applies to the camera and not to the accessories, such as the case and strap, nor does it apply to the battery and other consumables provided.
7. Any consequential damages arising from failure of the camera, such as expenses incurred in taking pictures or loss of expected profit, will not be reimbursed whether they occur during the warranty period or not.
8. The warranty is only valid domestically.
  - \*The above provisions refer to repairs offered free of charge, and do not limit your legal rights.
  - \*The intention of the above provisions is also described in the warranty card provided with this camera.
9. Parts essential to the servicing of the camera (that is, components required to maintain the functions and quality of the camera) will be available for a period of five years after the camera is discontinued.
10. Please note that if the camera is seriously damaged by flooding, submergence, infiltration of sand or mud, violent shocks or dropping, it may not be repairable, and restoration to its original condition may be impossible.



### Note

- Before sending the camera in for repair, check the battery and read the instruction manual again to ensure proper operation.
- Some repairs require a significant amount of time to be completed.
- When sending the camera to a service center, please include a note which describes the defective part and the problem as precisely as possible.
- Remove all accessories not related to the problem before sending the camera to the service center.
- Before taking any important pictures (such as at weddings, on trips abroad, etc.), test the camera to check operation and ensure proper functioning. We recommend that you keep this manual and spare battery on hand.
- This warranty does not apply to data stored on an SD Memory Card or in internal memory.

# INFORMATION TO THE USER

## USA FCC Part15 Class B

The equipment has been tested and found to comply with the limits for a Class B digital device, pursuant to part 15 of the FCC Rules. These limits are designed to provide reasonable protection against harmful interference in a residential installation. This equipment generates, uses, and can radiate radio frequency energy and if not installed and used in accordance with the instructions, may cause harmful interference to radio communications. However, there is no guarantee that interference will not occur in a particular installation. If this equipment does cause harmful interference to radio or television reception, which can be determined by turning the equipment off and on, then user is encouraged to try to correct the interference by one or more of the following measures:

- Reorient or relocate the receiving antenna.
- Increase the separation between the equipment and receiver.
- Connect the equipment to an outlet on a circuit different from that to which the receiver is connected.
- Consult the dealer or an experienced radio/TV technician for help. (FCC 15.105B)

Changes or modifications not expressly approved by the party responsible for compliance could void the user's authority to operate the equipment. (FCC 15.21)

Properly shielded and grounded cables and connectors must be used for connection to a host computer in order to comply with FCC emission limits. (FCC 15.27)

An AC adapter with a ferrite core must be used for RF interference suppression.

## COMPLIANCE INFORMATION STATEMENT

Product Name: DIGITAL CAMERA

Model Number: GR DIGITAL

This device complies with Part 15 of the FCC Rules.

Operation is subject to the following two conditions:

- (1) This device may cause harmful interference, and
- (2) This device must accept any interference received, including interference that may cause undesired operation.

RICOH CORPORATION

5 Dedrick Place, West Caldwell NJ, 07006 Tel.: 1-800-225-1899

## Note to Users in Canada

Note: This Class B digital apparatus complies with Canadian ICES-003

## Remarque Concernant les Utilisateurs au Canada

Avertissement: Cet appareil numérique de la classe Best conforme a la norme NMB-003 du Canada

IMPORTANT SAFETY INSTRUCTIONS-SAVE THESE INSTRUCTIONS

DANGER-TO REDUCE THE RISK OF FIRE OR ELECTRIC SHOCK, CAREFULLY FOLLOW THESE INSTRUCTIONS.



Declaration of Conformity

"The Product complies with the requirements of the EMC Directive 89/336/EEC."

# Index

---

## A

Acrobat Reader .....	155
ADJ BTN.SET. 1/2 .....	127
ADJ. Button .....	65
Auto Bracket .....	80
AUTO POWER OFF .....	128
Auto Power Off .....	29
AV Cable .....	10, 54

## B

BEEP SOUND .....	129
Browse CD-ROM .....	155

## C

Caplio Software CD-ROM .....	11, 153, 171
COLOR SPACE SET .....	143
CONT (Multi-Shot) .....	101
COPY TO CARD .....	119

## D

DATE IMPRINT .....	86
DENSITY .....	93
Direct Print .....	60
DirectX .....	155
DPOF .....	115

## E

Erasing .....	56
Error Message .....	197
EXPOSURE COMP. ....	87

## F

Flash .....	44
FOCUS .....	74
Focus-lock .....	40
FORMAT - CARD .....	124
FORMAT - INT. MEM. ....	125
Full-press .....	36

## G

Grid Guide .....	32
------------------	----

## H

Half-press .....	37
Handstrap .....	10
How to Hold the Camera .....	34

## I

Image Size .....	69
IMAGE WITH SOUND .....	85
IMG SET .....	78
INTERVAL .....	83
ISO SETTING .....	91

## L

LCD BRIGHTNESS .....	126
LCD CONFIRM. ....	131

## M

Macro-Mode .....	43
Magnifying Images .....	53
MANUAL FOCUS (MF) .....	72
Mounter .....	171

M (Memory-reversal) Multi-Shot .....	101
--------------------------------------	-----

## N

Number of Images That Can be Stored in Internal Memory/SD Memory Card .....	192
---	-----

## P

Packing List .....	10
PHOTOMETRY .....	77
PIC QUALITY/SIZE .....	69
PictBridge .....	60
Picture Quality Mode .....	69
PROTECT .....	112

## R

Rechargeable Battery .....	10
REG. MY SETTING .....	148
RESIZE .....	118
RESTORE DEFAULTS .....	92
RICOH Gate La .....	153, 171

## S

Scene .....	47
SD Memory Card .....	22
Self-timer .....	95
SEQUENTIAL NO. ....	132
Shooting Menu (Movie Mode) .....	190
SLIDE SHOW .....	111
Specifications .....	187
START SETTING .....	149
Synchro-Monitor Mode .....	32
S (Stream) Multi-Shot .....	101

## T

Thumbnail Display .....	52
Trouble .....	180
Troubleshooting .....	180

## U

Uninstalling .....	169
USB Cable .....	10
USB Driver .....	153, 154, 171

## W

Warranty and Servicing .....	198
WAV file .....	108
White Balance .....	88
White Balance Bracket .....	81
WIA Driver .....	153, 154

## Z

Zoom .....	42
ZOOM BTN. SET. ....	147

# Telephone Support Numbers in Europe

UK	(from within the UK)	02073 656 580
	(from outside of the UK)	+44 2073 656 580
Deutschland	(innerhalb Deutschlands)	06331 268 438
	(außerhalb Deutschlands)	+49 6331 268 438
France	(à partir de la France)	0800 91 4897
	(en dehors de la France)	+33 6331 268 409
Italia	(dall'Italia)	02 696 33 451
	(dall'estero)	+39 02 696 33 451
España	(desde España)	91 406 9148
	(desde fuera de España)	+34 91 406 9148
Nederland	(binnen Nederland)	0800 022 9494
	(vanuit het buitenland)	+49 6331 268 443

<http://www.service.ricohpmmc.com/>

# From environmental friendliness to environmental conservation and to environmental management

Ricoh is aggressively promoting environment-friendly activities and also environment conservation activities to solve the great subject of management as one of the citizens on our precious earth.



To reduce the environmental loads of digital cameras, Ricoh is also trying to solve the great subjects of "Saving energy by reducing power consumption" and "Reducing environment-affecting chemical substances contained in products".

## If a problem arises

First of all, see "Troubleshooting" in this manual. If the issues still persist, please contact a Ricoh office.

Ricoh Offices	
Ricoh Company, Ltd.	3-2-3, Shin-Yokohama Kohoku-ku, Yokohama-shi 222-8530, Japan <a href="http://www.ricoh.co.jp/r_dc">http://www.ricoh.co.jp/r_dc</a>
Ricoh Corporation	5 Dedrick Place West Caldwell, NJ 07006, USA 1-800-22RICOH <a href="http://www.ricoh-usa.com">http://www.ricoh-usa.com</a>
RICOH EUROPE B.V. (EPMMC)	Oberrather Straße 6, D-40472, Düsseldorf, Germany <a href="http://www.ricohpmmc.com">http://www.ricohpmmc.com</a>
RICOH UK LTD. (PMMC UK)	Ricoh House, 1 Plane Tree Crescent, Feltham, Middlesex, TW13 7HG, England
RICOH FRANCE S.A. (PMMC FRANCE)	383, Avenue du Général de Gaulle – BP 307-931-13 Clamart Cédex, France
RICOH ESPANA, S.A. (PMMC SPAIN)	Av. Litoral Mar, 12-14, 08005 Barcelona, Spain
RICOH EUROPE B.V. (PMMC BENELUX)	Koolhovenlaan 35, 1119 NB Schiphol-Rijk, The Netherlands
Ricoh Italia S.p.A. (PMMC ITALY)	via Ponchielli,3 20063 Cernusco S/N Milano Italy
RICOH HONG KONG LIMITED Personal Multimedia Products Center	21/F., Tai Yau Building, 181 Johnston Road, Wan Chai, Hong Kong
Ricoh Australia Pty. Ltd.	8 Rodborough Road Frenchs Forrest, N.S.W.2086 Australia <a href="http://www.ricoh.com.au">http://www.ricoh.com.au</a>
About ImageMixer	North America (Los Angeles): TEL: +1-213-341-0163 Europe (U.K.): TEL: +44-1489-564-764 Asia (Philippines): TEL: +63-2-438-0090 China: TEL: +86-21-5450-0391 Registration time: 9:00 - 17:00

Ricoh Company, Ltd.  
Minato-ku, Tokyo 107-8544, Japan  
2005 September



Printed in China



\* L 7 2 6 2 9 7 1 \*